

PROTECTION CAPS AND PROTECTION SETS

Example: Protection Caps M30 / M32 PTFE



PROTECTION CAP

The PTFE protection cap (PEEK and Delrin are also available) is designed for applications where the detected material is highly abrasive, e.g. granules. It is a protection cap for the front face of the sensor. Where there is damage due to abrasion one only has to change the protection cap and the sensor remains on good condition.

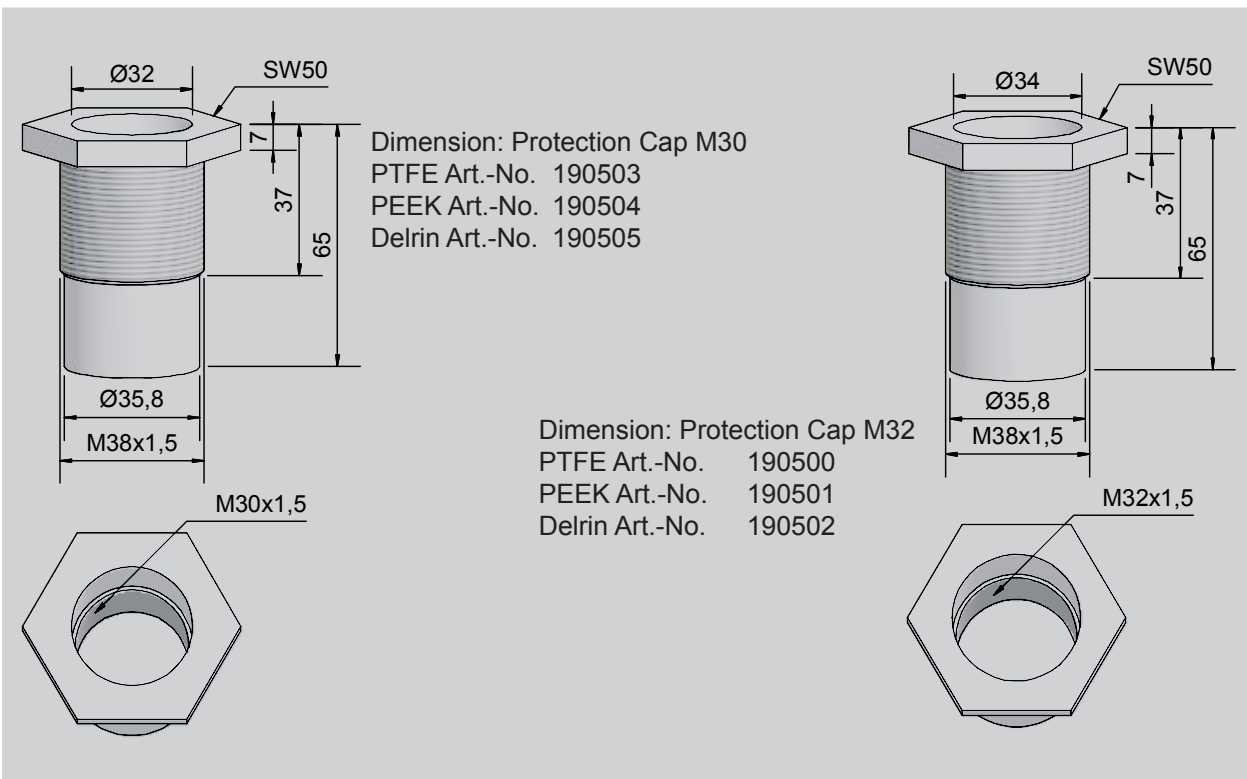

Example: Protection Set M32



Protection Set M18 Art.-No. 196305
Protection Set M30 Art.-No. 196302
Protection Set M32 Art.-No. 196301

PROTECTION SET

The PTFE protection set M 32 x 1.5 consists of an internally threaded cover, a Pg9-screwing for cable entry and a rubber gasket between the cover and the sensor. This protection cover serves as improvement to the degree of protection, against infiltration of liquids, for example in applications where the sensor is totally immersed in liquids. The resistance of the material still needs to be checked.

The thread of the sensor has to be sealed, for example with PTFE sealing-tape. The protection cover has to be screwed totally up to the end, and then the Pg-screw has to be fixed.

All specifications are subject to change without notice. (07/2011)