

IMX-A830

Features

- Multichannel amplifier with modulated infrared light
- 8-channel installation system for tight assembly without cross talk
- Automatic Level Control (ALC) according to assembly distance and direction
- Range up to 55 m (180 ft)
- One transistor output for each channel (NPN/PNP)
- Test function to check installation and signal strength
- Programmable light/dark function
- Programmable basic transmit level
- Switching-on and switching-off delay (0 - 7 s)
- Master-Slave mode
- Transmitter and receiver terminals are short circuit proof

Safety Instructions



Warning!

The infrared light barriers IMX-A830 are not safety systems and should not be used as such systems. The devices are not to be used for applications, where personal safety is dependent on their function.

Short Description

This 8-channel automatic multiplexer Pantron has set a new standard for devices of this type. It is an amplifier with an integrated analysis unit. Up to eight transmitters and receivers can be connected to each unit without possibility of cross talk. The amplifier works with modulated infrared light which provides high immunity to ambient light. The automatic gain setting enables the user to simplify the installation and work.

Each channel has a transistor output (NPN/PNP) and a status LED. All channels can be switched independent from each other to the different working conditions. The sensitivity of the device can be switched to 2 basic transmit levels. Also, the transmitter power can be increased to optimize object recognition.

A control unit, which can be activated by simply pressing a button, is used to determine malfunctions in the transmitter or the receiver. If nothing is defective, the test function shows the signal quality by flashing an LED from 1 to 10 times. The flashes are proportional to the received signal.

An alarm display and output, which shows errors and the limit of the transmit power and is connectable with a PLC, enables users to safely work with the photoelectric amplifier.

Infrared transmitters and receivers in different, compact and robust designs are described in the sensor heads datasheet.



Ordering Table

Operation voltage	Order code
230 V AC	IMX-A830/230VAC
115 V AC	IMX-A830/115VAC
24 V AC	IMX-A830/24VAC
24 V DC	IMX-A830/24VDC
Accessories	Order code
Protective enclosure	PanBox 1x8

Device Overview

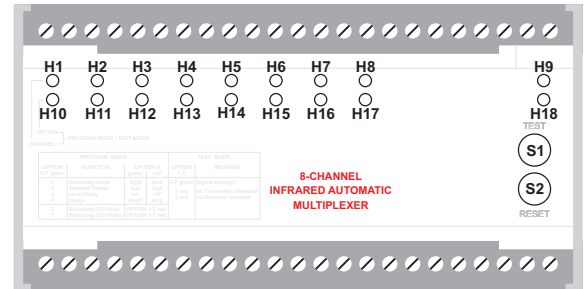

Displays and operating elements

- H1-8 – Output status indicator (yellow)
- H9 – Operation mode display (green/yellow)
- H10-17 – Multi function display (green/yellow/red)
- H18 – Slave mode (yellow)
- S1 – Test button
- S2 – Reset button

IMX-A830

Technical Data (at 20 °C / 68 °F)

Operating voltage ...AC	230 V AC, 115 V AC, 24 V AC / ±10%	
Operating voltage ...DC	24 V DC / ±10%	
Power consumption (max.)	...AC: 10 VA	...DC: 10 W
Power loss (max.) (EN 61439)	...230 VAC: 7,6 W	...24VDC: 6,3 W
	...115 VAC: 7,4 W	
	...24VAC: 7,4 W	
Operating basis	modulated infrared light	
Transmit frequency	4,0 kHz	
Transmit power	automatic	
Basic transmit level	low / high	
Switching behavior	light / dark	
Multiplex speed	34 ms (30 Hz)	
Switching delay	0...15 s	
Light curtain function	yes	
ALC delay	2 s, programmable	
Master slave function	yes	
MTBF (IEC 61709)	0,8 · 10 ⁶ h (T _{ambient} = 40 °C / 104 °F)	
Operation temperature	-25 °C ... 60 °C (-13 °F ... 140 °F)	
Storage temperature	-40 °C ... 80 °C (-40 °F ... 176 °F)	
Housing material	plastic (Makrolon 8030)	
Protection class (EN 60529)	IP20	

Mounting	top hat rail EN 60715 or 2 holes (DIN 46121)	
Electrical connection	screw terminal, 4,0 mm ²	
Mounting orientation	free	
Dimensions (mm)	L 75 x B 150 x H 110	
Switching output	1 transistor output per channel (NPN/PNP)	
Switching data (max.)	100 mA / 24 V DC	
Reaction time	36 ms	
Switching frequency	15 Hz	
Alarm output	pnp	
Switching data (max.)	IMX-A830...AC: 5 mA / 24 V DC IMX-A830/24VDC: 100 mA / 24 V DC	
Test input	—	
Analog output	—	
COM interface	—	
max. Range (through beam)	Receiver IRL-...	Receiver IR-..., IRH-...
Transmitter IT-..., ITL-...	8 m (26 ft)	15 m (49 ft)
Transmitter IT-...HP, ITH-...	10 m (33 ft)	20 m (66 ft)
Transmitter ITA-...	20 m (66 ft)	55 m (180 ft)

Connection Diagram



Caution!

Before connecting the amplifier, look on the type plate and check if the power supply is the same as the connection value. Other values can impair the unit functions or destroy the amplifier.

The AC-supply devices are isolated from main. A grounded connection on the low voltage side is required.

In synchronized operation of multiple devices (master/slave), we recommend installation using short connecting cables.

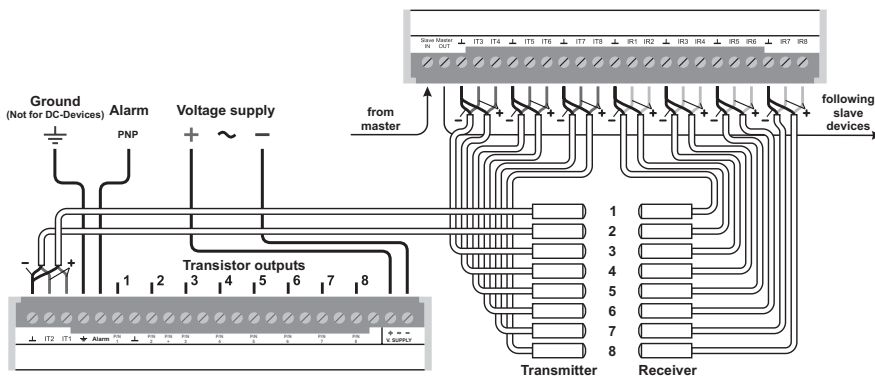

NPN-circuit

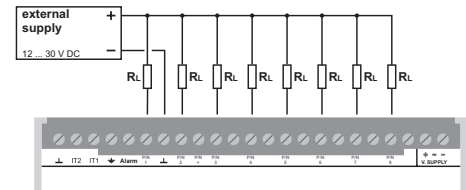

PNP-circuit

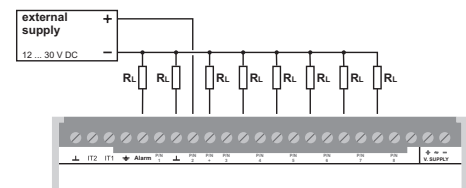

Dimensions (in mm)

