

IMX-A2034...

Features

- Multichannel amplifier with modulated infrared light
- 2-channel installation system for tight assembly without cross talk
- Range up to 40 m (131 ft)
- Automatic Level Control (ALC) according to assembly distance and direction
- High immunity to ambient light and interference from other light barriers
- Test function to check installation and signal strength
- Adjustment assistance for easy adjustment of the sensor heads
- Switch-on and switch-off delay
- Switching mode light/dark switchable
- Four basic transmit levels
- One relay output (Form A) for each channel
- Transmitter and receiver connections are short-circuit proof
- 11-pin DIN railmounting socket for simple installation

Ordering Table

Supply voltage	Order code
230 V AC	IMX-A2034/230VAC
115 V AC	IMX-A2034/115VAC
24 V AC	IMX-A2034/24VAC
24 V DC	IMX-A2034/24VDC
Accessories	Order code
11-pin DIN mounting socket	ISO1
Protective enclosure	PanBox 1x2
Retaining clip	RTC11

Safety Instructions



Warning!

The infrared light barriers IMX-A2034... are not safety systems and should not be used as such systems. The devices are not to be used for applications, where personal safety is dependent on their function.

Short Description

The 2-channel automatic multiplexer is an processor controlled amplifier with an integrated analysis unit. Up to two transmitters and receivers can be connected to each unit without possibility of cross talk. The automatic gain setting and the adjustment assistance enables the user to simplify the installation and work.

The amplifier has for each channel one relay output (Form A) and a yellow status LED.

All channels can be switched independently from each other to the different working conditions. To make fine adjustments to the sensitivity of the amplifier based on the range and contamination level of the application, the user may switch to different transmit levels using DIP switches.

A control unit, which can be activated by simply pressing a button, is used to determine malfunctions in the transmitter or the receiver.

If nothing is defective, the test function shows the signal quality by flashing an LED from 1 to 10 times. The flashes are proportional to the received signal.

Infrared transmitters and receivers in different, compact and robust designs are described in the sensor heads datasheet.



Device Overview

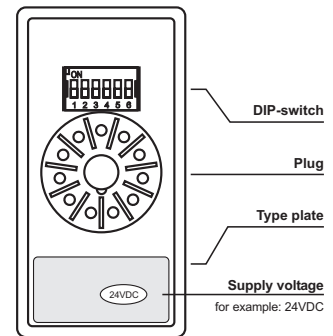
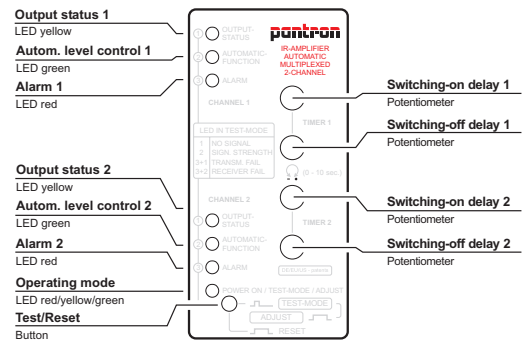

DIP-switch setting

DIP-switch	1	2	3	4	5	6
	basic transmit level channel 1		switching mode channel 1	basic transmit level channel 2		switching mode channel 2
	high2	ON ON	dark	ON	high2	ON ON
	high1	ON OFF	light	OFF	high1	ON OFF
	low2	OFF ON	light	OFF	low2	OFF ON
	low1	OFF OFF	light	OFF	low1	OFF OFF

Factory setting is marked in dark grey

Switching logic

Beam status	Switching mode	Output status	
		Indicator	Relay output
	light		
	dark		
	light		
	dark		

IMX-A2034...

Technical Data (at 20 °C / 68 °F)

Supply voltage ...AC	230/115/24 V AC / ±10%	
Supply voltage ...DC	24 V DC / ± 10%	
Power consumption (max.)	...AC: 5,1 VA	...DC: 2,6 W
Power loss (max.) (EN 61439)	...AC: n. a.	...DC: 2,6 W
max. Range (through beam)	Receiver IRL-...	Receiver IR-..., IRH-...
Transmitter IT-..., ITL-...	7 m (ft)	13 m (ft)
Transmitter IT-...HP, ITH-...	9 m (ft)	20 m (66 ft)
Transmitter ITA-...	15 m (ft)	40 m (131 ft)
Operating basis	modulated IR-light	
Transmit frequency	4,0 kHz	
System power	automatic	
Switching behavior	light / dark	
Basic transmit level	Low 1 / Low 2 / High 1 / High 2	
Switching delay	0 ... 10 s	
Multiplex speed	4 ms	

Relay output	1 normally open contact per channel
Switching data (max.)	5A / 230 V AC (24 V DC)
Reaction time T _{ON} / T _{OFF}	25 ms / 25 ms
Transistor output	—
Alarm output	—
Test input	—
MTBF (EN/IEC 61709)	1,7 · 10 ⁶ h (T _{ambient} = 40 °C / 104 °F)
Operating temperature	-25 °C ... 60 °C (-13 °F ... 140 °F)
Storage temperature	-40 °C ... 80 °C (-40 °F ... 176 °F)
Housing material	Plastic
Housing protection	IP 40
Mounting	11-pin DIN socket
Mounting orientation	free
Dimensions	40,0 x 76,5 x 78,5 mm

Connection Diagram



Before connecting the amplifier, look on the type plate and check if the power supply is the same as the connection value. Other values can impair the unit functions or destroy the amplifier.

Caution! The AC-supply devices are isolated from main. A grounded connection on the low voltage side is required (PIN 7).

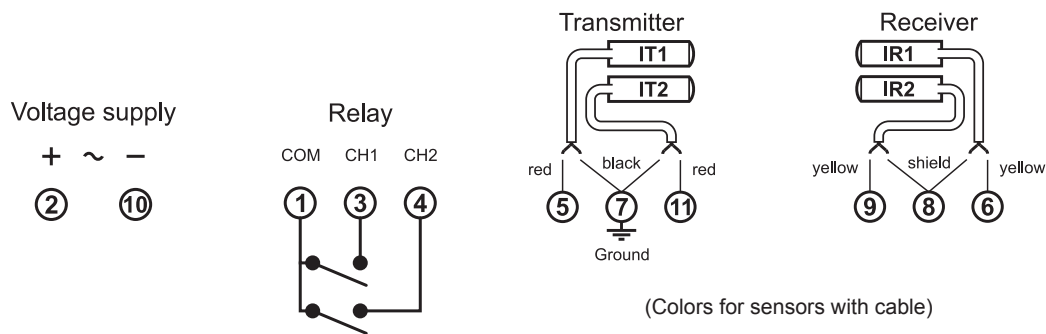

Dimensions (in mm)

