

SAFEMASTER Interface Module HC 3096N, HL 3096N

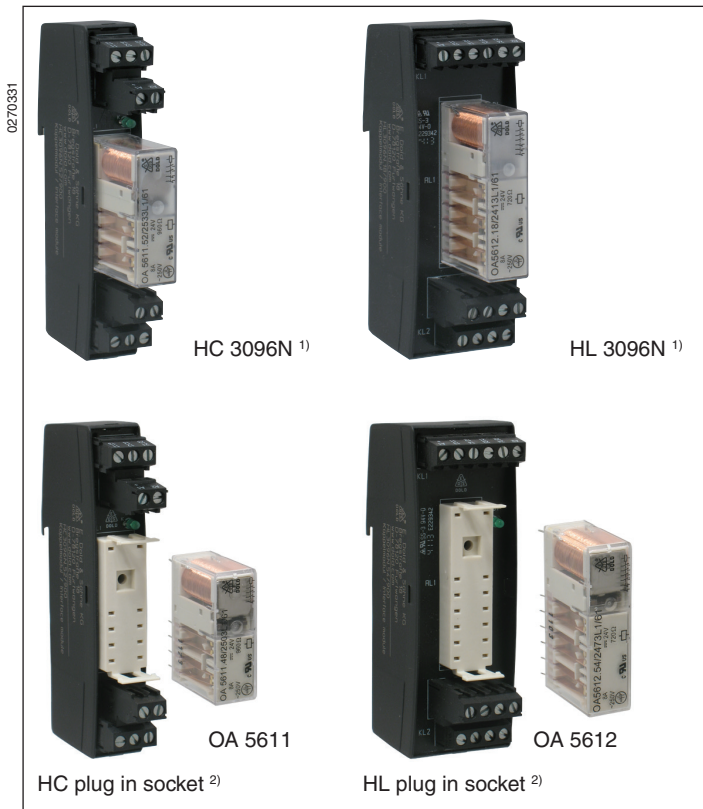

Your Advantages

- Simple contact extension and re-inforcement also of safety modules
- Cost and space saving alternative compared to contactors
- Simple contact monitoring via forcibly guided NC contact
- large wire cross section 0.5 - 2.5 mm² (12-24 AWG) reduces thermal load on wires

Features

- According to DIN EN 61810-1, IEC 60664-1, IEC/EN 60 947-5-1
- With forcibly guided contacts according to IEC 61810-3
- Models with soldered in or plug-in PCB safety relay consisting of:
 - plug in socket HC 3096N and safety relay OA 5611
 - plug in socket HL 3096N and safety relay OA 5612
- With polarity protected diode
- Optionally with free-wheeling diode across A1+ and A2
- Optionally AgNi + 0,2 µm Au or AgNi + 5 µm Au
- For DIN rail mounting according IEC/EN 60715
- HC 3096N:width 18 mm
- HL 3096N:width 36 mm

Approvals and Markings



Circuit Diagrams

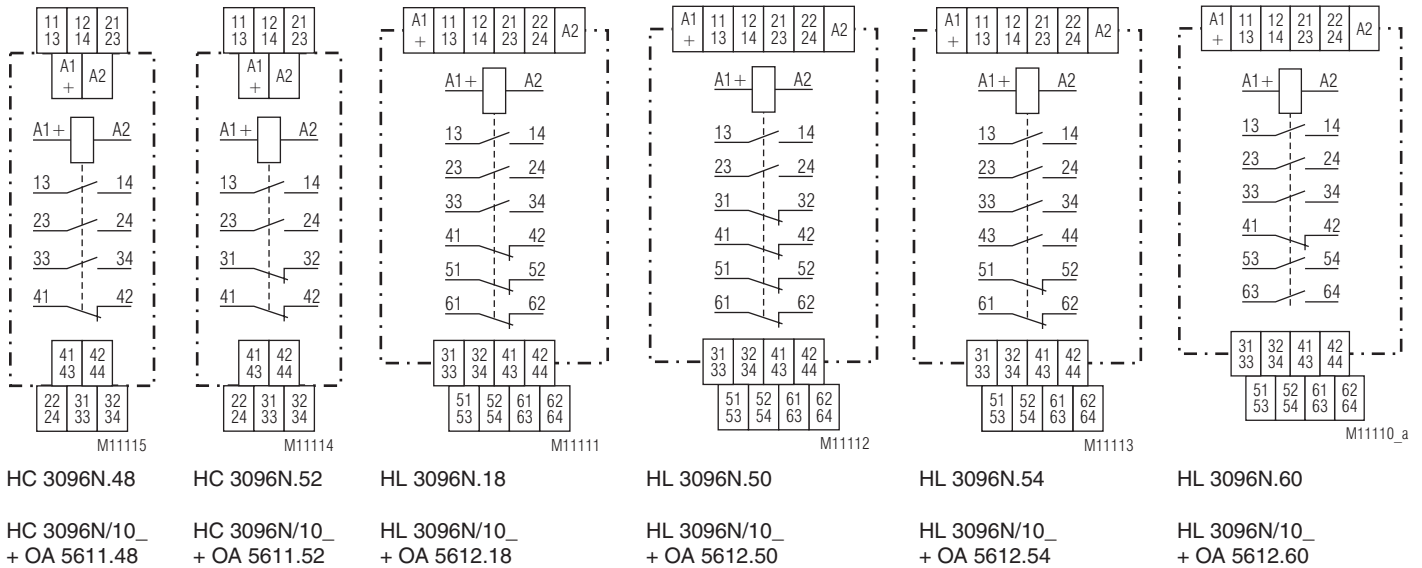

Connection Terminals

Terminal designation	Signal description
A1+	L / +
A2	N / -
41, 42 / 61, 62	NC contact
All other contacts see relevant circuit diagram	NC contacts / or NO contacts

Technical Data

Input

Nominal voltage U_N:	DC 24, 60, 110 V other voltages on request
Voltage range:	0.8 ... 1.1 U_N
Nominal consumption	
HC 3096N:	0.6 W
HL 3096N:	0.8 W
HL 3096N.50:	1.0 W

Output

Contacts:

HC 3096N.52, OA 5611.52:	2 NO and 2 NC contacts
HC 3096N.48, OA 5611.48:	3 NO and 1 NC contacts
HL 3096N.18, OA 5612.18:	3 NO and 3 NC contacts
HL 3096N.50, OA 5612.50:	2 NO and 4 NC contacts
HL 3096N.54, OA 5612.54:	4 NO and 2 NC contacts
HL 3096N.60, OA 5612.60:	5 NO and 1 NC contacts

Contact material: AgNi + 0.2 μ m Au, AgNi + 5 μ m Au
other on request

Contact type: spring contact

Operate time: typical 20 ms

Release time: typical 6 ms

Measured nominal voltage: AC 250 V

Thermal current I_{th}

HC 3096N: 3 x 5 A

HL 3096N: 5 x 5 A

Switching capacity

to AC 15

NO contact: 2 A / AC 230 V IEC/EN 60947-5-1

NC contact: 1 A / AC 230 V IEC/EN 60947-5-1

to DC 13

NO contact: 1 A / DC 24 V IEC/EN 60947-5-1

NC contact: 1 A / DC 24 V IEC/EN 60947-5-1

according to DC 13

NO contact: 4 A / 24 V at 0.1 Hz

NC contact: 4 A / 24 V at 0.1 Hz

Electrical life

HC 3096N

to AC 230 V / 5 A $\cos\phi = 1$: $\geq 2 \times 10^5$ switching cycles

HL 3096N

at DC 24 V / 5 A ohmic: $\geq 2 \times 10^5$ switching cycles

Permissible switching

frequency: 10 switching cycles / s

Switching voltage min./max.: AC/DC 10 V / AC/DC 250 V
(AC/DC 2 V / AC/DC 60 V for
AgNi-contacts + 5 μ m Au)

Switching current min./max.: 10 mA / 5 A

(2 mA / 0,3 A for
AgNi-contacts + 5 μ m Au)

Switching power min./max.: 0.1 VA / 2000 VA
(10 mVA / 12 VA for
AgNi-contacts + 5 μ m Au)

0.1 W / 200 W
(10 mW / 12 W for
AgNi-contacts + 5 μ m Au)

Short circuit strength

max. fuse rating: 6 A gG / gL IEC/EN 60947-5-1

Mechanical life: $\geq 50 \times 10^6$ switching cycles

General Data

Operating mode: Continuous operation

Temperature range:

Operation: - 40 ... + 55 °C

Storage: - 40 ... + 70 °C

Relative air humidity: 93 % at 40 °C

Altitude: < 2,000 m

Clearance and creepage distances

rated impulse voltage /

pollution degree

Input / output

HC devices: 6 kV / 2 IEC 60664-1

HL devices: 4 kV / 2 IEC 60664-1

output / output: 4 kV / 2 IEC 60664-1

Overvoltage category: III

Insulation test voltage,

type test: 2,5 kV; 1 min

Technical Data

EMC

Electrostatic discharge:	8 kV (air)	IEC/EN 61000-4-2
HF-irradiation		
80 MHz ... 1 GHz:	20 V / m	IEC/EN 61000-4-3
1 GHz ... 2.7 GHz:	10 V / m	IEC/EN 61000-4-3
Fast transient:	4 kV	IEC/EN 61000-4-4
Surge voltages		
between		
wires for power supply:	1 kV	IEC/EN 61000-4-5
between wire and ground:	2 kV	IEC/EN 61000-4-5
HF-wire guided:	10 V	IEC/EN 61000-4-6
Interference suppression:	Limit value class B	EN 55011

Degree of protection

Housing: IP 40 IEC/EN 60529

Terminals: IP 20 IEC/EN 60529

Housing: Thermoplastic

Vibration resistance: Amplitude 0.35 mm

Frequency 10 ... 55 Hz, IEC/EN 60068-2-6

Humid heat IEC/EN 60068-2-30

Climate resistance: Humid heat IEC/EN 60068-2-30

Terminal designation: EN 60947-1

Wire connection: 0.5 ... 2,5 mm² solid

0.5 ... 2,5 mm² flexible

Captive slotted screw

0,5 Nm

Mounting: DIN rail IEC/EN 60715

Weight

HC 3096N: approx. 71 g

HL 3096N: approx. 90 g

Dimensions

Width x height x depth

HC 3096N: 18 x 106 x 65 mm

HL 3096N: 36 x 106 x 65 mm

UL Data

Nominal voltage U_N : DC 6 ... 110 V

Switching capacity:

Ambient temperature 60 °C: Pilot duty B300
5 A 250Vac G. P.
5 A 24Vdc
0.4 A 250Vac resistive

Wire connection: 60°C / 75°C copper conductors only
AWG 24 - 12 torque value 4.4 lb-in



Technical data that is not stated in the UL-Data, can be found in the technical data section.

Classification to DIN EN 50155

Vibration and

shock resistance: Category 1, Class B IEC/EN 61373

Ambient temperature: T1 and T2 compliant

T3 and TX with operational limitations

Voltage range: 0.7 ... 1.25 U_N with operational limitations

Protective coating of the PCB: No

Standard Types with soldered relay

HC 3096N.48/400 DC 24 V

Article number: 0066000

• 3 NO, 1 NC contact

• AgNi + 0.2 μ m Au

• Width: 18 mm

HL 3096N.54/400 DC 24 V

Artikelnummer: 0066040

• 4 NO, 2 NC contact

• AgNi + 0.2 μ m Au

• Width: 36 mm

Ordering Example

H_3096N_ / _ /61 DC 24 V

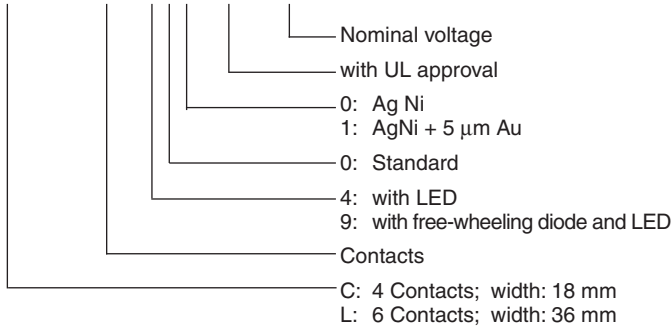

Standard Types for plug in relay

Plug in socket

HC 3096N/102/61 DC 24 V: With free-wheeling diode and LED
Article number: 0066018

Suitable relay: OA 5611.48/2503L1
3 NO, 1 NC
Contact material: AgNi + 0.2 µm Au
Article number: 0047318
or
OA 5611.52/2533L1
2 NO, 2 NC
Contact material: AgNi
Article number: 0047321

Plug in socket

HL 3096N/102/61 DC 24 V: With free-wheeling diode and LED
Article number: 0066334

Suitable relay: OA 5612.18/2413L1
3 NO, 3 NC
Contact material: AgNi + 0.2 µm Au
Article number: 0047950

further variantes on request

Ordering example

H_3096N / 10_ /61 DC 24 V

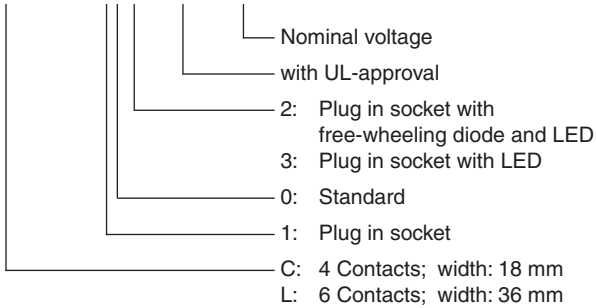

Characteristic

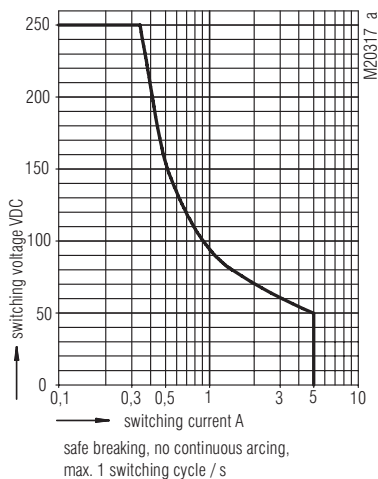

Arc limit curve under resistive load

Characteristic

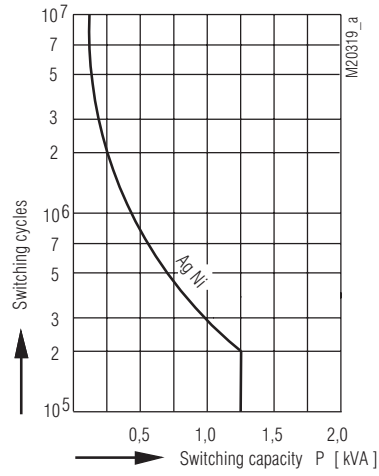

Contact service life

Connection Example for HC 3096N/10_ /61

Relay: OA 5611.52 ≅ 2 NO contacts and 2 NC contacts (Standard)

A1+	A2	Contact	Contact-type	Connection
{ 11 13 12 14 }	{ 21 23 22 24 }	1	NO contact	13, 14
		2	NO contact	23, 24
{ 41 43 42 44 }	{ 31 33 32 34 }	3	NC contact	31, 32
		4	NC contact	41, 42

The terminal assignment is according to the diagram on the installed relay

Connection Example for HC 3096N/10_ /61

Relay: OA 5612.18 ≅ 3 NO contacts and 3 NC contacts (Standard)

A1+	A2	Contact	Contact-type	Connection
{ 11 13 12 14 }	{ 21 23 22 24 }	1	NO contact	13, 14
		2	NO contact	23, 24
{ 41 43 42 44 }	{ 31 33 32 34 }	3	NO contact	33, 34
		4	NC contact	41, 42
{ 51 53 52 54 }	{ 61 63 62 64 }	5	NC contact	51, 52
		6	NC contact	61, 62

The terminal assignment is according to the diagram on the installed relay

Safety Notes

Dangerous voltage.
Electric shock will result in death or serious injury.

Disconnect all power supplies before servicing equipment.

- Faults must only be removed when the relay is disconnected
- The user has to make sure that the device and corresponding components are installed and wired according to the local rules and law (TUEV, VDE, Health and safety).
- Installation work must only be done when power is disconnected.

Dimensions with safety relay

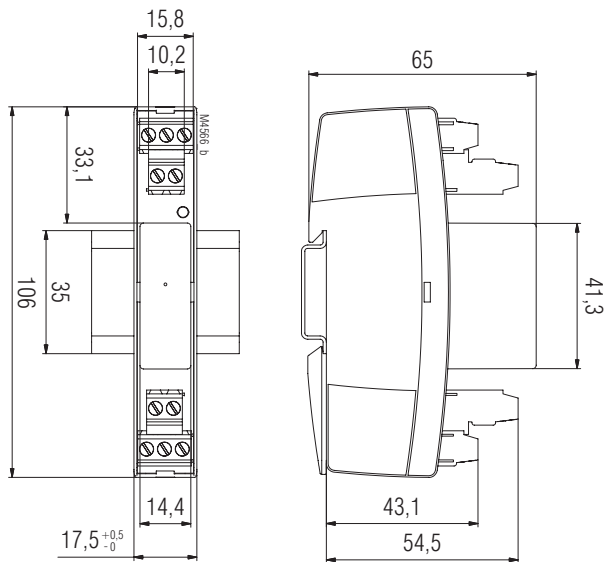

HC 3096N

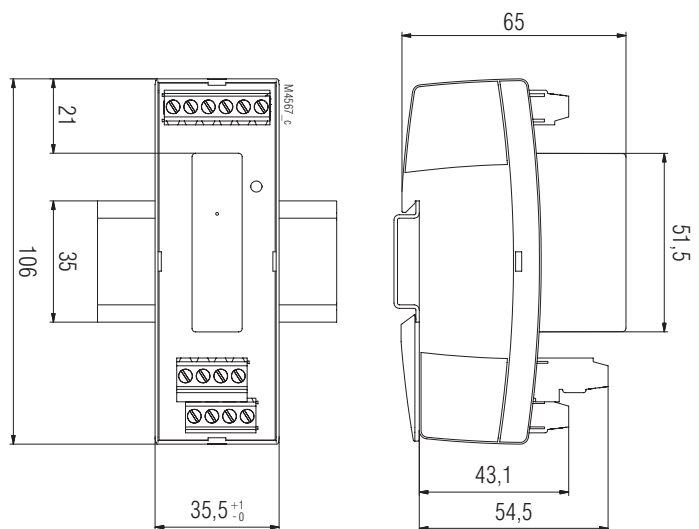

HL 3096N

Dimensions with plug in socket

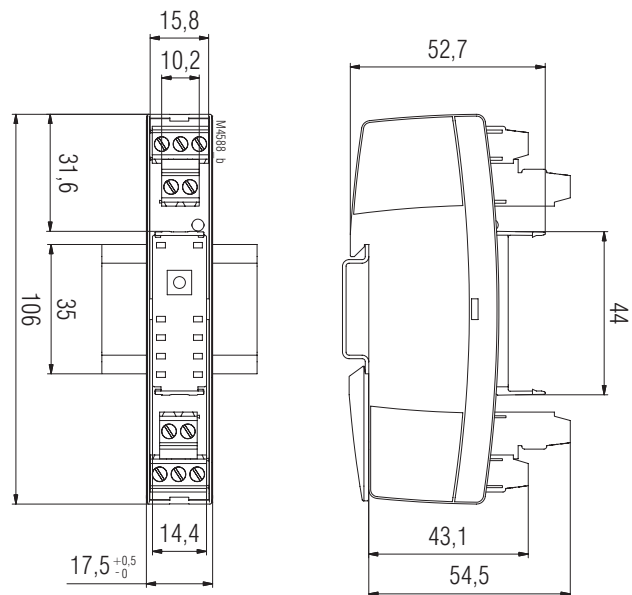

HC 3096N

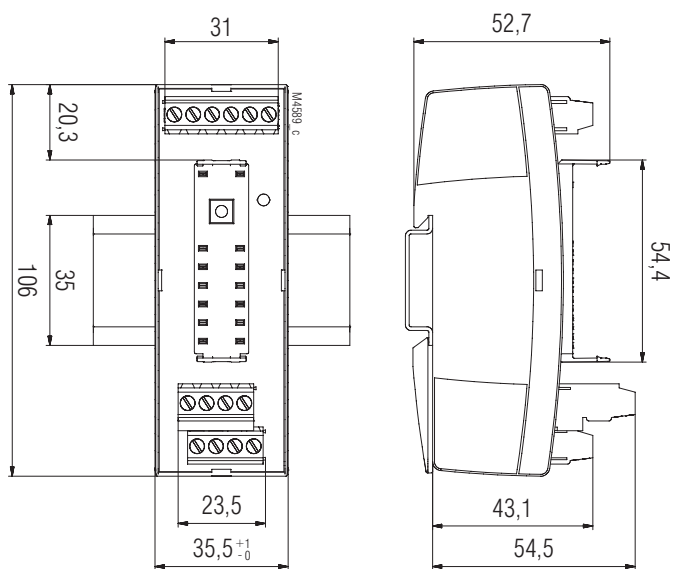

HL 3096N