

**POWERSWITCH**  
**Solid-State Contactor**  
**BF 9250, BH 9250**

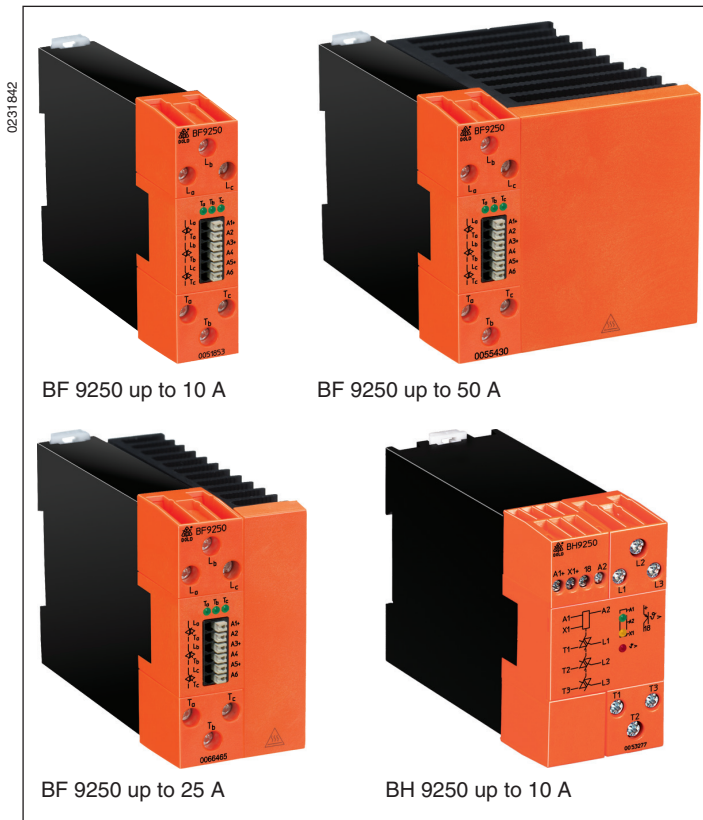

- According to IEC/EN 60 947-4-2, IEC/EN 60 947-4-3
- 1-, 2- and 3-pole models
- Load current up to 50 A
- For AC load up to 480 V
- Switching at zero crossing
- Protected by varistors
- As option temperature protection of the power semiconductors with monitoring output
- Mounting on DIN-rail
- As option with control input X1 with low current consumption e.g. to be controlled by a PLC
- As option up to 3 separate semiconductor contactors in one unit
- BF 9250: width 22.5 mm, 45 mm and 90 mm
- BH 9250: width 45 mm, 67.5 mm and 112.5 mm

**Approvals and Markings**



**Function Diagram**

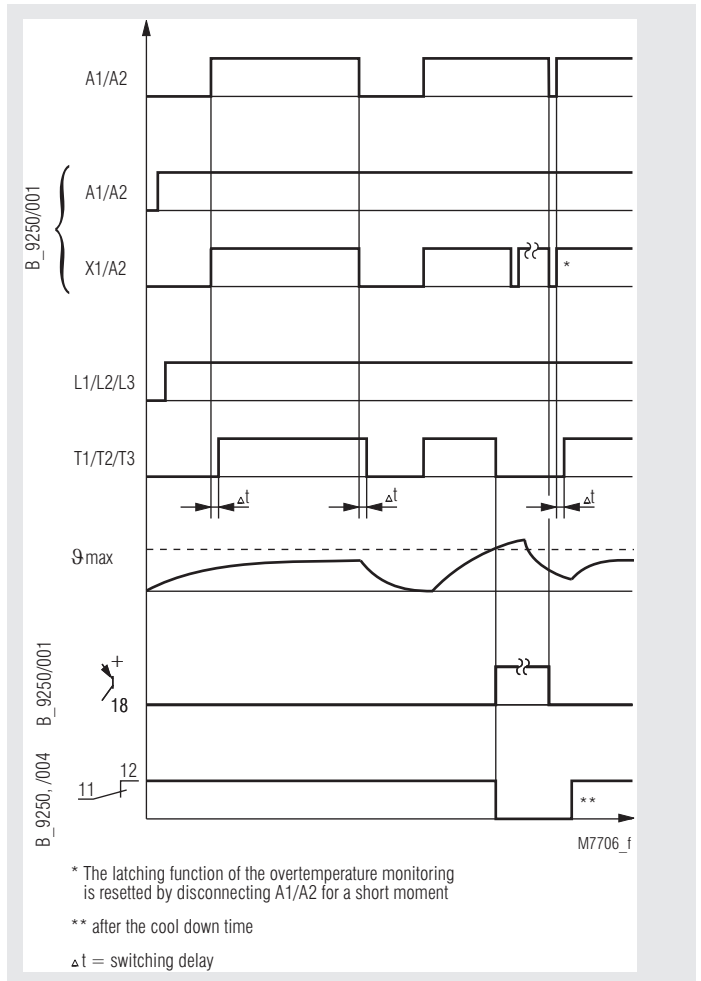

**Applications**

Fast and noiseless switching of:

- heating elements
- motors
- valves
- lighting

**Indicators**

**BF 9250/001, BH 9250/001, BH9250/006**  
 green LED "A1-A2": on, when voltage on A1/A2  
 yellow LED "x1": on, when voltage on X1  
 red LED "ϑ>": on, when overtemperature

**BF 9250/003**  
 green LED "T<sub>a</sub>": on, when A1 connected  
 green LED "T<sub>b</sub>": on, when A3 connected  
 green LED "T<sub>c</sub>": on, when A5 connected

**BF 9250/004**  
 green LED "T<sub>a</sub>": on, when A1 connected  
 green LED "T<sub>b</sub>": on, when A2 connected  
 green LED "T<sub>c</sub>": on, when A3 connected

**BF 9250**  
 green LED "A1-A2": on, when voltage on A1

## Block Diagrams

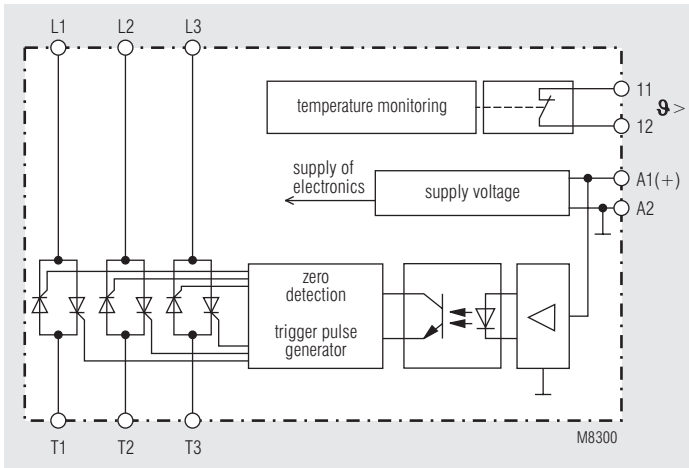

BF 9250, BF 9250/004

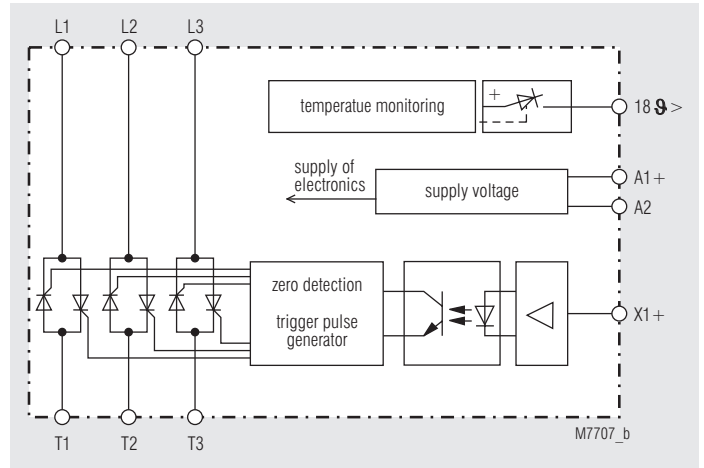

BF 9250/001, BH 9250/001

## Circuit Diagrams

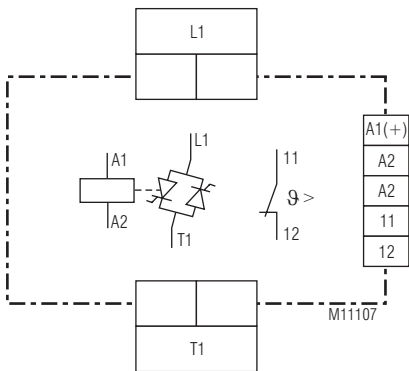

BF 9250.01

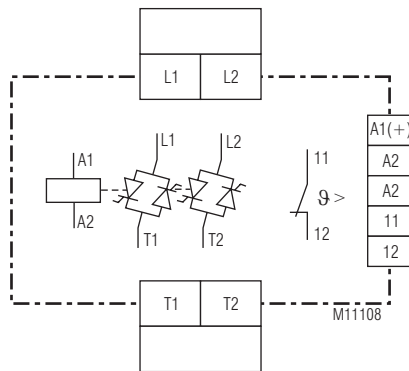

BF 9250.02

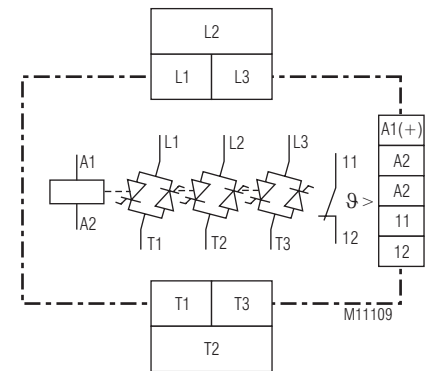

BF 9250.03

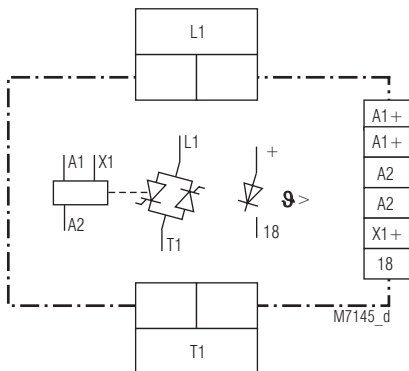

BF 9250.01/001

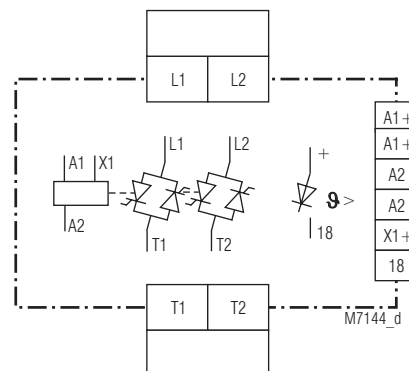

BF 9250.02/001

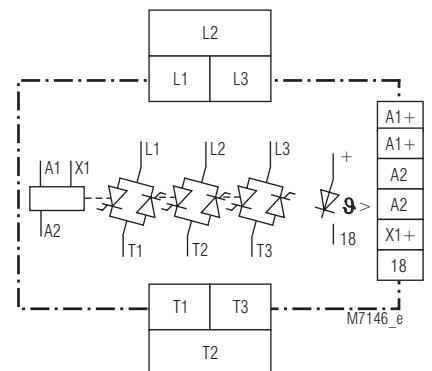

BF 9250.03/001

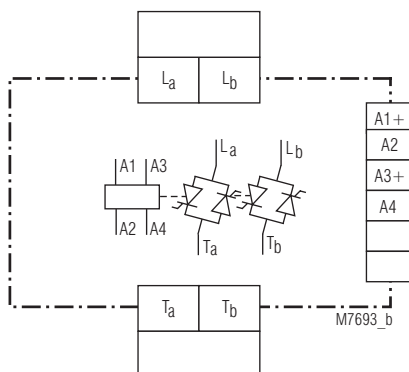

BF 9250.92/003

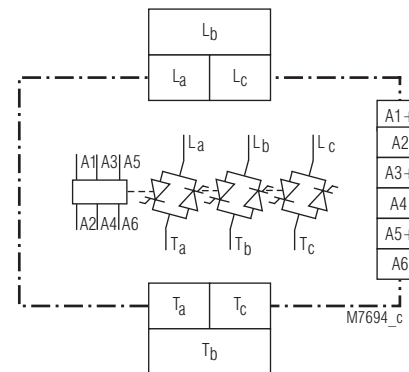

BF 9250.93/003

## Connection Terminals

Terminal designation	Signal description
A1, A2, A3, A4, A5, A6, COM, X1	Control or operating voltage
18	Indicator output
11, 12	NC contact
L1, L2, L3	Mains connections
T1, T2, T3	Load outputs
T1b, T2b	Load outputs

## Circuit Diagrams

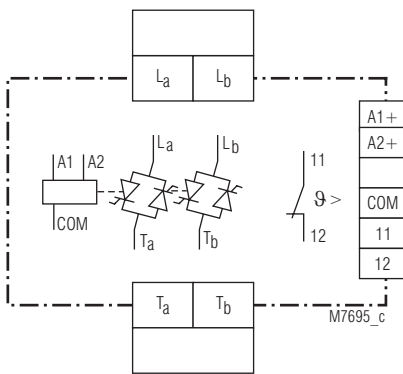

BF 9250.02/004

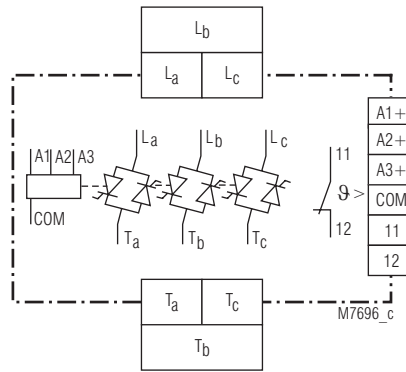

BF 9250.03/004

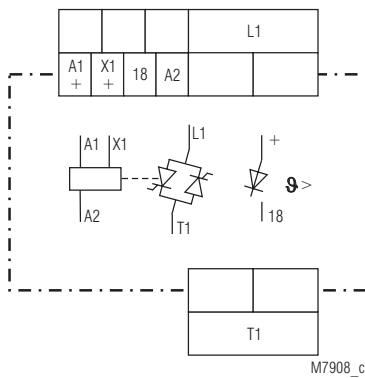

BH 9250.01/001

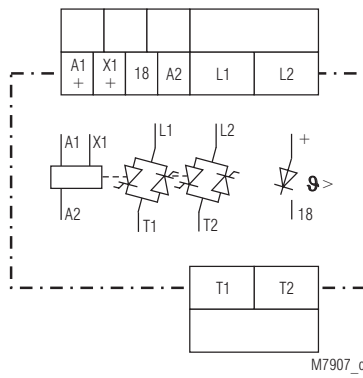

BH 9250.02/001

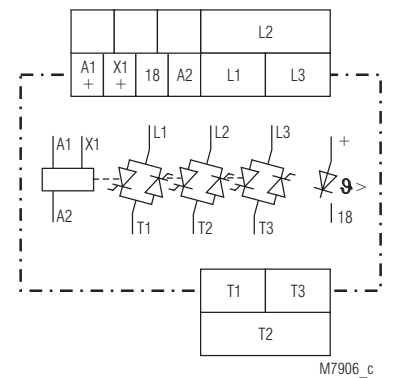

BH 9250.03/001

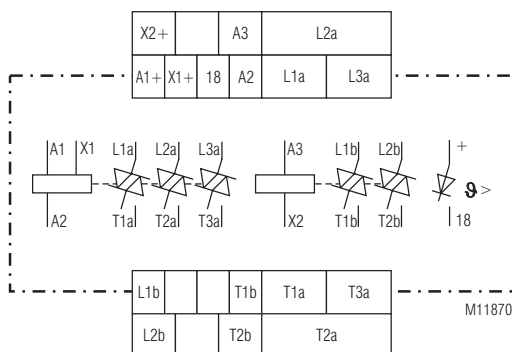

BH 9250.03/006

## Technical Data

### Input

#### BF 9250/001, BH 9250/001:

Operation voltage A1/A2:	DC 24 V
Voltage tolerance:	± 10 %
Input current:	35 mA
Control voltage X1/A2:	DC 3 ... 48V
Making voltage:	DC 3 V
Switch off voltage:	DC 2 V
Start current:	0,5 mA at DC 3 ... 10 V 10 mA at DC 10 ... 48 V
Start up delay [ms]:	≤ 2 + 1/2 Periode
Release delay [ms]:	≤ 1 + 1/2 Periode

#### BF 9250/003:

Control voltage A1/A2:	DC 24 V, control of T <sub>a</sub>
Control voltage A3/A4:	DC 24 V, control of T <sub>b</sub>
Control voltage A5/A6:	DC 24 V, control of T <sub>c</sub>
Start up delay [ms]:	≤ 1 + 1/2 Periode
Release delay [ms]:	≤ 1 + 1/2 Periode

#### BF 9250/004:

Control voltage A1/COM:	DC 24 V, control of T <sub>a</sub>
Control voltage A2/COM:	DC 24 V, control of T <sub>b</sub>
Control voltage A3/COM:	DC 24 V, control of T <sub>c</sub>
Start up delay [ms]:	≤ 1 + 1/2 Periode
Release delay [ms]:	≤ 1 + 1/2 Periode

#### BF 9250:

Control voltage A1/A2:	AC/DC 110 ... 230V, AC/DC 24 V
Start up delay [ms]:	≤ 3 + 1/2 Periode
Release delay [ms]:	≤ 35 + 1/2 Periode

#### BH 9250/006:

Operation voltage A1+/A2:	DC 24 V
Control voltage X1+/A2:	DC 3 ... 48 V
Control voltage X2+/A3:	DC 24 V

### Output

#### Load output T1, T2, T3; T<sub>a</sub>, T<sub>b</sub>, T<sub>c</sub>

#### Load currents at 100 % duty cycle ED, AC 51:

BF 9250 BH 9250	Ambient temperature	Device without heat sink	Device with small heat sink	Device with large heat sink
1-pole	25°C	13 A	30 A	55 A
	40°C	10 A	25 A	50 A
2-pole	25°C	7 A	17,5 A	28 A
	40°C	6,5 A	15 A	25 A
3-pole	25°C	6 A	14 A	20 A
	40°C	5 A	10 A	15 A

#### BH 9250.03/006:

#### Load output T1a, T2a, T3a

#### AC-51 3 x 3 A

#### Load output T1b, T2b

#### AC-51 2 x 1 A

#### Current reduction over 40°C

BF 9250 BH 9250	Device without heat sink	Device with small heat sink	Device with large heat sink
1-pole	0,2 A / °C	0,4 A / °C	0,6 A / °C
2-pole	0,2 A / °C	0,3 A / °C	0,4 A / °C
3-pole	0,2 A / °C	0,2 A / °C	0,3 A / °C

#### Min. load current:

AC 40 mA

#### Load voltage range:

AC 24 ... 480 V

#### Frequency range:

50 / 60 Hz

#### Leakage current in off state at nominal voltage U<sub>N</sub> and nominal frequency

#### (T<sub>J</sub>=125°C, max.):

1.0 mA

#### at load voltage up to:

AC 480 V

#### Peak inverse voltage:

± 1200 Vp

## Technical Data

### Short circuit current

at t=10 ms

BF 9250.01; .02; .92;

BH 9250.01; .02:

600 A

BF 9250.03; .93;

BH 9250.03:

400 A

### Power dissipation:

P = 1.2 [V] x I eff. [A] / k [W]  
with k as formfactor and  
k = 1.1 for sinusoidal current

### Semiconductor fuse

BF 9250 BH 9250	I <sub>N</sub>	load limit integral of the semiconductor	Semiconductor fuse		
			Type	Article-No.	Brand
1-pole	10 A	1800 A <sup>2</sup> s	fuse 10 x 38	6003434.16	SIBA
	25 A	1800 A <sup>2</sup> s	fuse 10 x 38	6003434.30	SIBA
	50 A	1800 A <sup>2</sup> s	NH-00	2020920.63	SIBA
2-pole	2x6,5 A	1800 A <sup>2</sup> s	fuse 10 x 38	6003434.10	SIBA
	2x15 A	1800 A <sup>2</sup> s	fuse 10 x 38	6003434.20	SIBA
	2x25 A	1800 A <sup>2</sup> s	fuse 10 x 38	6003434.30	SIBA
3-pole	3x5 A	800 A <sup>2</sup> s	fuse 10 x 38	6003434.8	SIBA
	3x10 A	800 A <sup>2</sup> s	fuse 10 x 38	6003434.16	SIBA
	3x15 A	800 A <sup>2</sup> s	fuse 10 x 38	6003434.20	SIBA

### Varistor voltage:

AC 510 V

### Semiconductor Monitoring Output

#### Output (Terminal 18):

transistor, plus switching

#### switched auxiliary voltage:

DC 24 V

#### Switching capacity:

100 mA, short circuit proof

#### Residual voltage:

typ. 0.6 V

#### Output (NC contact 11, 12)

#### Switching capacity:

AC 240 V\* / 2.0 A cos φ = 1

AC 240 V\* / 1.0 A cos φ = 0.6 inductive

DC 24 V / 1.0 A

\*) max. AC 150 V at variant /004

### General Data

#### Fitting position:

cooling ribs vertically

#### Operating mode:

Continuous operation

#### Temperature range:

Operation:

0 ... 40°C

max. 60°C (with current derating factor see table)

- 20 ... + 80°C

#### Storage temperature:

#### Clearance and creepage distances

rated impulse voltage /

pollution degree

4 kV / 3

IEC 60 664-1

#### EMC

IEC/EN 61 000-6-4, IEC/EN 61 000-6-1

Electrostatic discharge:

8 kVair / 6 kV contact IEC/EN 61 000-4-2

HF-irradiation:

10 V / m

IEC/EN 61 000-4-3

Fast transients:

2 kV

IEC/EN 61 000-4-4

Surge voltages between

wires for power supply:

1 kV

IEC/EN 61 000-4-5

between wire and ground:

2 kV

IEC/EN 61 000-4-5

HF-wire guided:

10 V

IEC/EN 61 000-4-6

Interference suppression:

Limit value class A IEC/EN 60 947-4-3

A higher suppression class can be reached by connecting capacitors of 0.47 µF / 600 V AC across the phases or across phase and neutral.

## Technical Data

### Insulation voltages

Input to Output:	2.5 kV
Input to semiconductor monitoring output (NC contact)	2.0 kV
Input to heat sink:	2.5 kV
Output to Output:	2.5 kV
Output to heat sink:	2.5 kV

### Degree of protection

Housing:	IP 40	IEC/EN 60 529
Terminals:	IP 20	IEC/EN 60 529

### Vibration resistance:

Amplitude 0,35 mm  
Frequency 10 ... 55 Hz, IEC/EN 60 068-2-6  
0 / 060 / 04 IEC/EN 60 068-1

### Climate resistance:

### Terminal designation

### Wire connection:

DIN 46 228-1/-2/-3/-4  
Load terminals:  
1 x 10 mm<sup>2</sup> solid  
1 x 6 mm<sup>2</sup> stranded ferruled

Control terminals and indicator outputs

BF 9250: 1 x 0.75 mm<sup>2</sup> stranded ferruled (isolated)  
DIN 46 228-1/-2/-3/-4  
1 x 1.5 mm<sup>2</sup> stranded ferruled

DIN 46 228-1/-2/-3

BH 9250: 1 x 4 mm<sup>2</sup> solid or  
1 x 2.5 mm<sup>2</sup> stranded ferruled (isolated) or  
2 x 1.5 mm<sup>2</sup> stranded ferruled (isolated)  
DIN 46 228-1/-2/-3/-4 or  
2 x 2.5 mm<sup>2</sup> stranded ferruled  
DIN 46 228-1/-2/-3

### Wire fixing

Load terminals: Terminal screws M 4  
Box terminal with wire protection

Control terminals:

BF 9250, BF 9250/001,  
BF 9250/003, BF 9250/004:  
BH 9250:

cage clamp terminals "Push-In"  
Plus-minus terminal screws M3,5  
box terminals with wire protection  
DIN rail IEC/EN 60 715

### Mounting:

### Weight

BF 9250	
Width 22.5 mm:	350 g
Width 45 mm:	580 g
Width 90 mm:	1 050 g
BH 9250	
Width 45 mm:	394 g
Width 67.5 mm:	638 g
Width 112.5 mm:	1 094 g

### Dimensions

#### Width x height x depth:

BF 9250:	22.5 x 85 x 120 mm
	45 x 85 x 120 mm
	90 x 85 x 120 mm
BH 9250:	45 x 85 x 120 mm
	67,5 x 85 x 120 mm
	112.5 x 85 x 120 mm

## UL-Data according to UL508

### Input

Wire connection:	60°C / 75°C copper conductors only
BF 9250:	AWG 28 - 14 Sol/Str
BH 9250:	AWG 20 - 12 Sol, 20 - 14 Str. Torque 0.8 Nm

### Load circuit

Fixed screw terminal:	75°C copper conductors only AWG 18 - 8 Sol Torque 0.8 Nm or AWG 18 - 10 Str Torque 0.8 Nm (only possible at variants up to 30 A)
-----------------------	---

**Temperature range:** 0 ... 40 °C

**Frequency range:** 50 / 60 Hz

**Pollution degree:** 2

In the final circuit an overvoltage protector R/CSPD (VZCA2/8) with min. 480V AC, 50/60Hz, VPR=2500V, Type 3 has to be installed.



Technical data that is not stated in the UL-Data, can be found in the technical data section.

## Standard Types

BF 9250.01/001 DC 24 V AC 24 ... 480 V 50/60 Hz 10 A

Article number: 0050515

- 1-pole
- Control input X1: DC 3 ... 48 V
- Auxiliary voltage: DC 24 V
- Load voltage: AC 24 ... 480 V
- Load current: 10 A
- With signal output
- Width: 22,5 mm

BF 9250.03/001 DC 24 V AC 24 ... 480 V 50/60 Hz 3 x 10 A

Article number: 0050520

- 3-pole
- Control input X1: DC 3 ... 48 V
- Auxiliary voltage: DC 24 V
- Load voltage: AC 24 ... 480 V
- Load current: 3 x 10 A
- With signal output
- Width: 45 mm

## Variants

BF 9250.0\_: Without low current input X1  
BH 9250.\_\_/001: With bigger diameter for control wires

BF 9250.92/003,  
BF 9250.93/003: 2 or 3 power semiconductor controlled by a separate input with galvanic isolation, without temperature monitoring of the semiconductors

BF 9250.02/004,  
BF 9250.03/004: 2 or 3 power semiconductor controlled by a separate input with common ground with temperature monitoring of the semiconductors signal output not latching without LED display of  $\varnothing$ .

## Ordering example for variants

BF 9250 .01 / \_ \_ \_ DC 24 V AC 24 ... 480 V 50/60 Hz 50 A

- Load current
- Frequency range
- Load voltage
- Auxiliary voltage  $U_H$
- Variant, if required
- 1-pole
- Type

## Installation

Recommended distance:  
upper / lower side to cable duct: 20 mm

Distance on left and right: 10 mm; with max. load current and 100 % duty cycle

# Application Examples

## single phase system

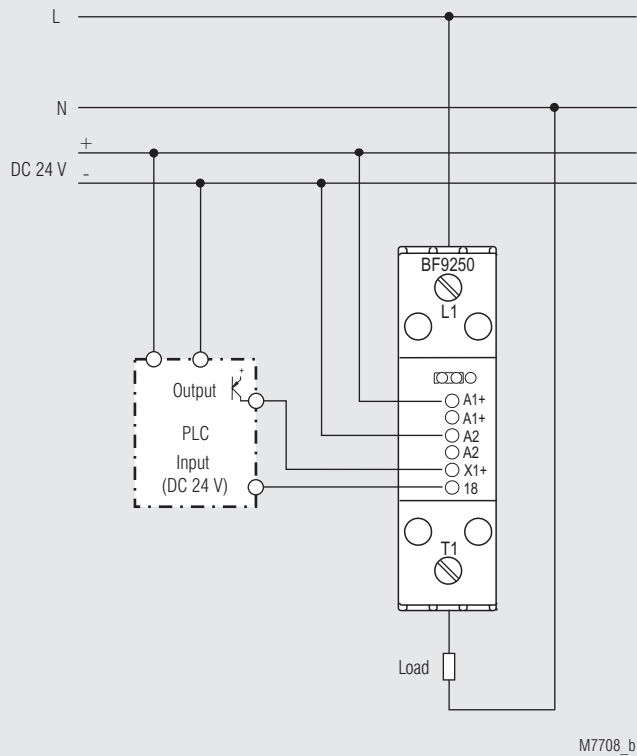

M7708\_b

## 3-phase system, 2 phases controlled

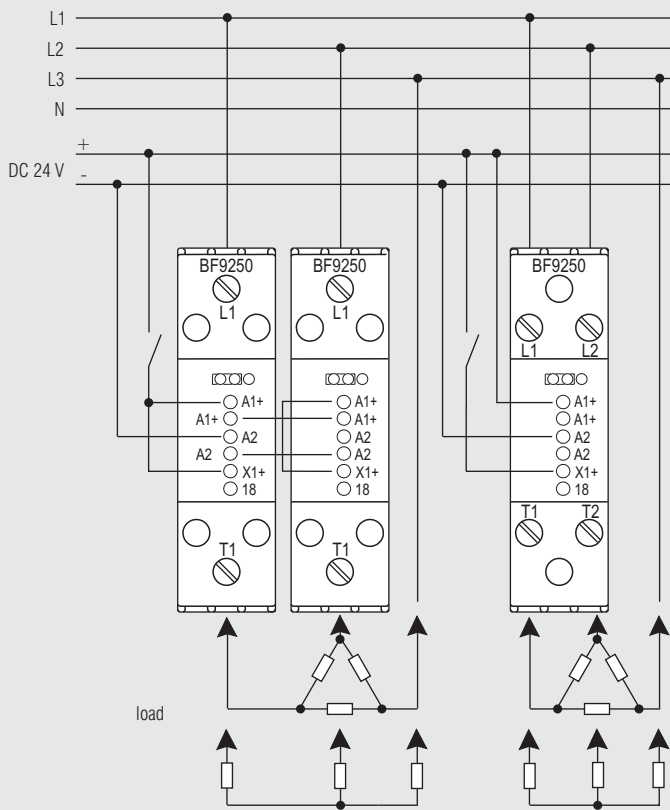

M9632

Single phase load switched by 1-pole semiconductor contactor controlled from PLC or Temperature controller output.

3-phase load, switched by 2 single-pole semiconductor contactors (left side) or by 1 2-pole semiconductor contactor (right side)

Width mm	22,5	45	90		22,5	45	90		22,5	45	90
I <sub>n</sub> / phase	10 A	25 A	50 A		10 A	25 A	50 A		10 A	25 A	50 A

BF 9250.\_.\_/001

## Application Examples

### 3-phase system, 3-phases controlled

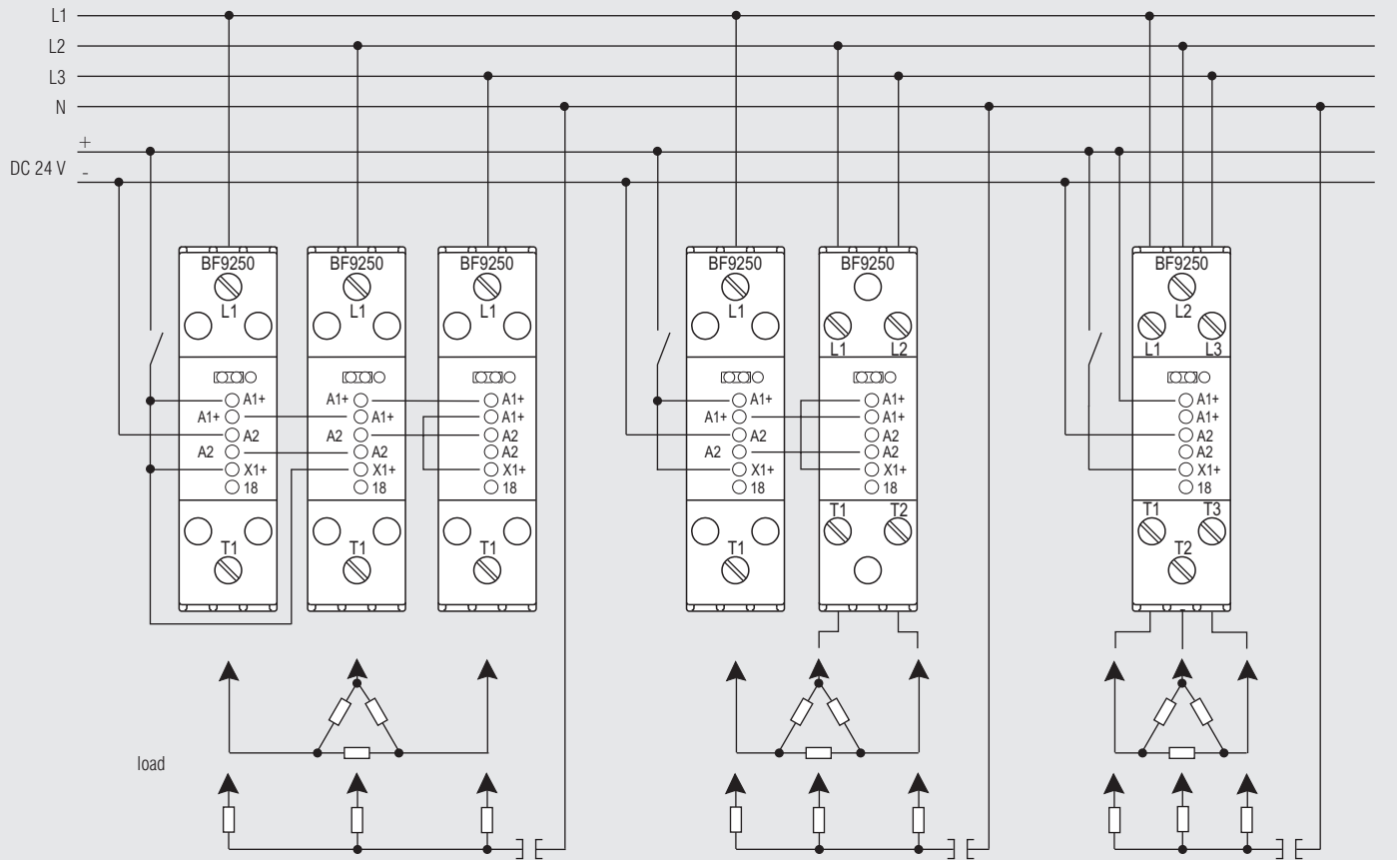

M9633

3-phase load switched by 3 single-pole semiconductor contactors

3-phase load switched by 1 3-pole semiconductor contactor

Width mm	22,5	45	90		22,5	45	90		22,5	45	90
$I_L$ / phase	10 A	25 A	50 A		6,5 A	15 A	25 A		5 A	10 A	15 A

BF 9250.\_.\_/001

**Application Examples**

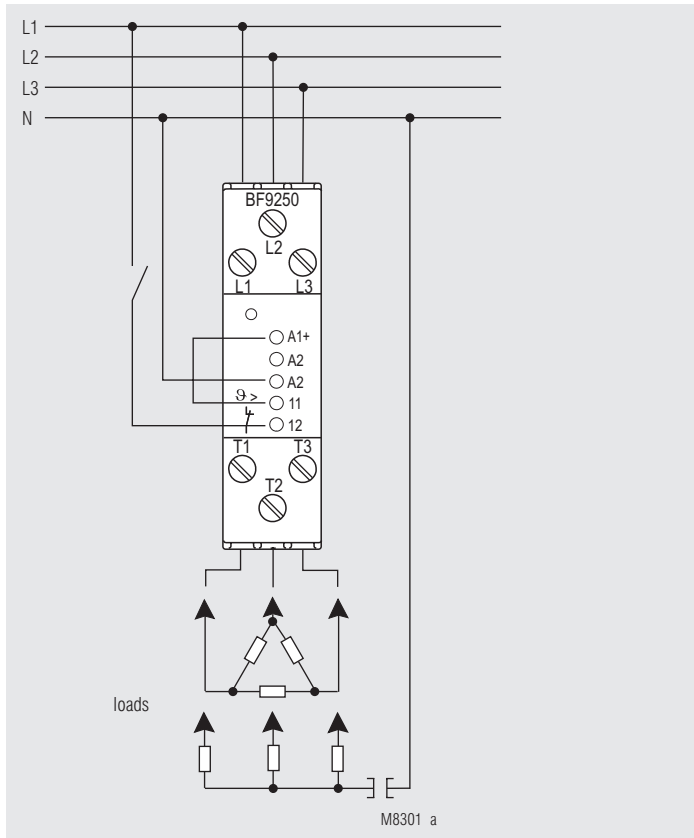

**BF 9250.03**  
3-phase load, controlled by a 3-pole semiconductor contactor with AC/DC 110-230 V control voltage.

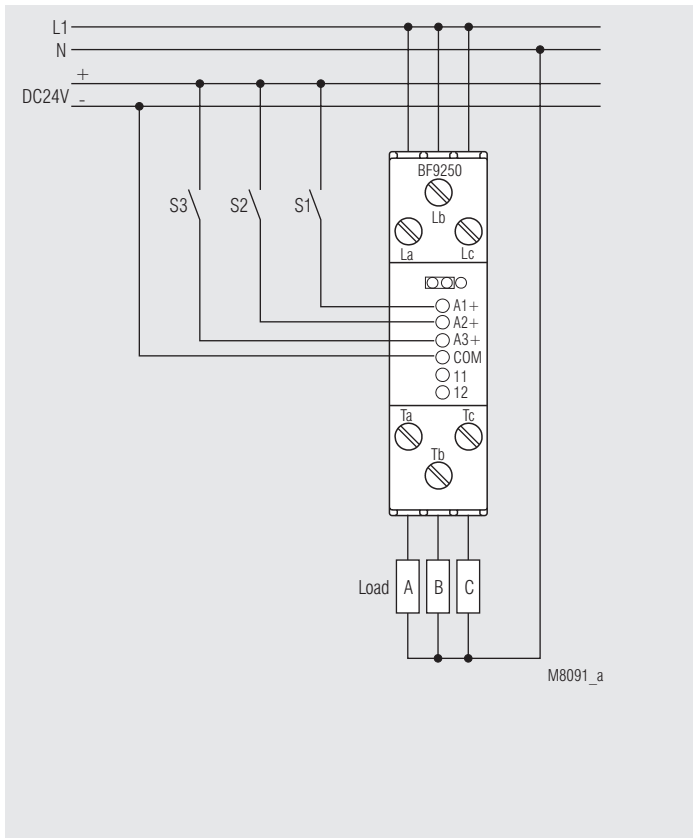

**BF 9250.03/004**  
3 semiconductor contactors in one housing control 3 different loads