

## SHB-M5-8-12 Sensor Holder

- Set includes adapter plate and ball joint
- Universal mounting possibility
- Smooth adjustment
- For a quick and easy fix and mounting of sensors
- Central ball joint adjustment
- Stainless steel / steel galvanized

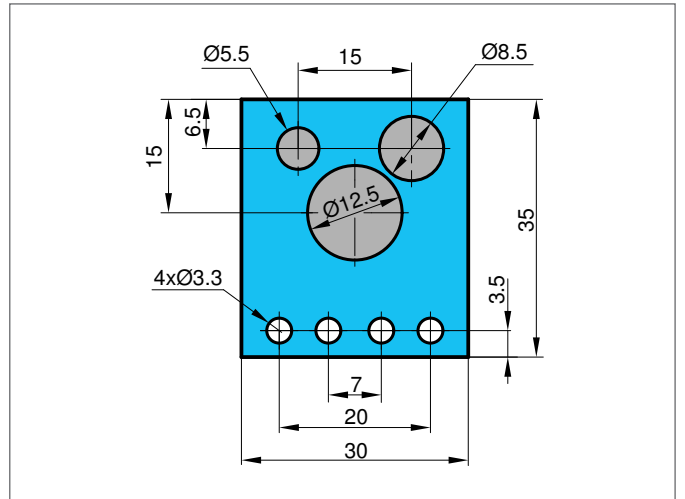
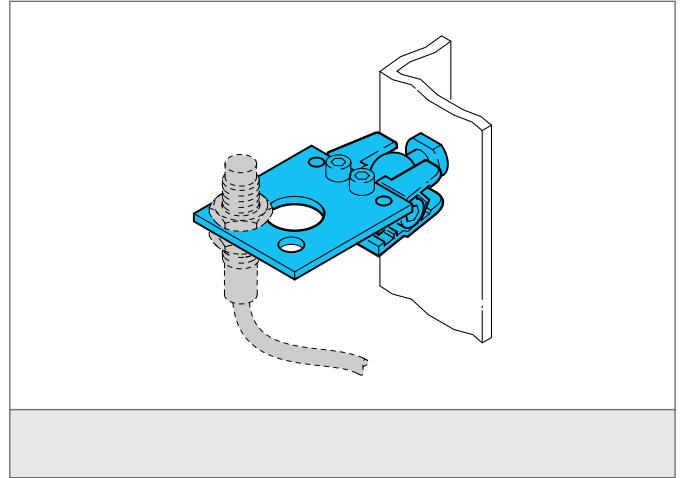

### TECHNICAL INFORMATION (typ.)

Mounting	Screw mounting M6 x 10
Suitable for	Cylindrically designed casings 5, 8 and 12 mm
Casing material	Steel galvanized