

- 线性模拟量范围很大
- 重复定位精度非常高
- 纠偏，也适用于透明材料
- 对尘土不敏感

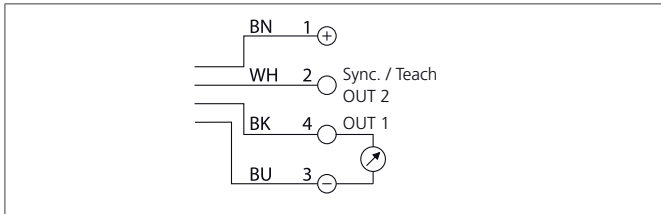

Safety instructions

The Instruments are not to be used for safety applications, in particular applications in which safety of persons depends on proper operation of the instruments.
These instruments shall exclusively be used by qualified personnel.

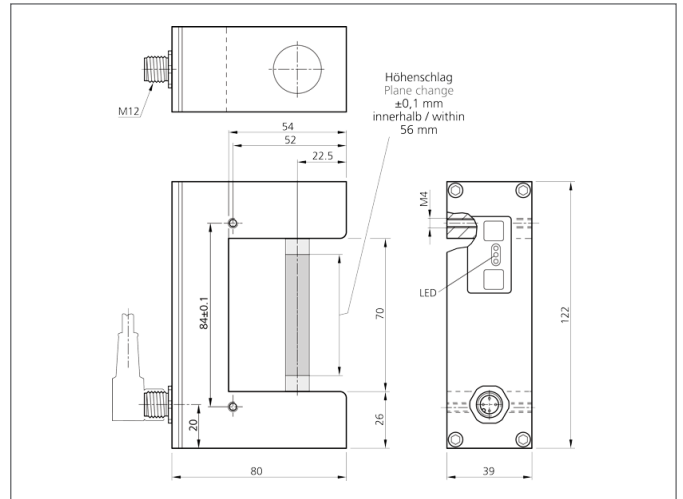

TECHNICAL INFORMATION (typ.)		+20°C, 24V DC
操作原理		超声波对射传感器
评估		模拟量
设计		槽型
槽口宽度/测量范围		70/13 mm
工作电压		8 ... 30 V DC
内部功耗		35 mA
灵敏度调节		示教键
模拟量输出		10 ... 0 V, Load / < 10000
涟漪		10 %
负载振荡		10 ... 55 Hz / 1,0 mm / 30 g
工作频率		285 Hz
重复定位精度		0.1 mm
绝缘电压		500 V
防护等级		IP 67
外壳材料		Aluminium black anodized
连接		Connector, M12, 4-poled