

# DCCR 40 K 20 PSOL-KL

## Inductive Proximity Switch

- Sensor probe pivotable as well as rotatable
- Connection clamps
- Integrated amplifier
- Protection against short-circuit and reverse polarity
- Starting pulse suppression
- LEDs for service voltage and output status
- 4-way LED indicator for 360° visibility

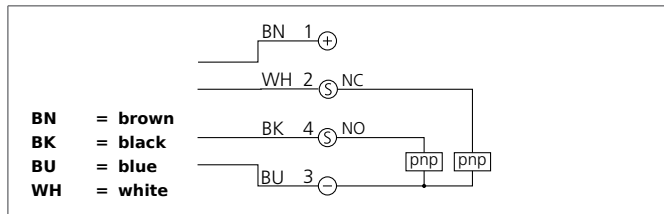

### Safety instructions

The Instruments are not to be used for safety applications, in particular applications in which safety of persons depends on proper operation of the instruments.  
 These instruments shall exclusively be used by qualified personnel.

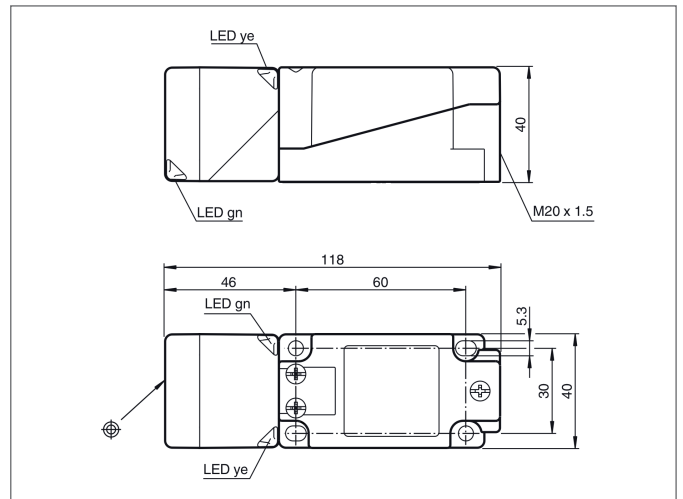

TECHNICAL INFORMATION (typ.)	+20°C, 24V DC
Operating principle	Inductive
Evaluation	digital
Size	40 x 40 x 118 mm (Dimensions)
Design	cuboid design
Mounting	flush
Operating distance	20 mm
Maximum rating	short-circuit-proof, polarity-safe
Standardized measuring plate	45 x 45 x 1 mm
Service voltage	10 ... 30 V DC
No-load current	< 20 mA
Switching output	pnp, 200 mA, exclusive OR
Switching hysteresis	5 %
LED indicator	yes
Shock-/vibration load	10 ... 55 Hz / 1,0 mm / 30 g
Voltage drop	< 2,0 V
Switching frequency	0 ... 150 Hz
Ambient temperature, operation	-25 ... +85 °C
Protection class	IP 68, IP 69K
Protection degree	II
Casing material	PA / metal with epoxy powder coating
Connection	clamps