

- 集成的放大器
- 防止短路
- 启动脉冲抑制
- LED
- 金属插头

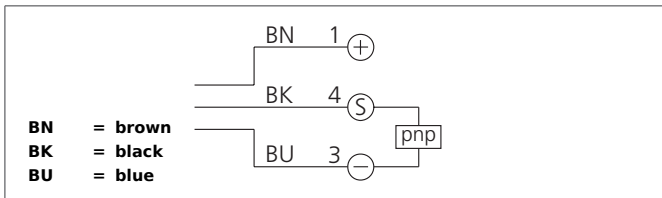

Safety instructions

The Instruments are not to be used for safety applications, in particular applications in which safety of persons depends on proper operation of the instruments.
 These instruments shall exclusively be used by qualified personnel.

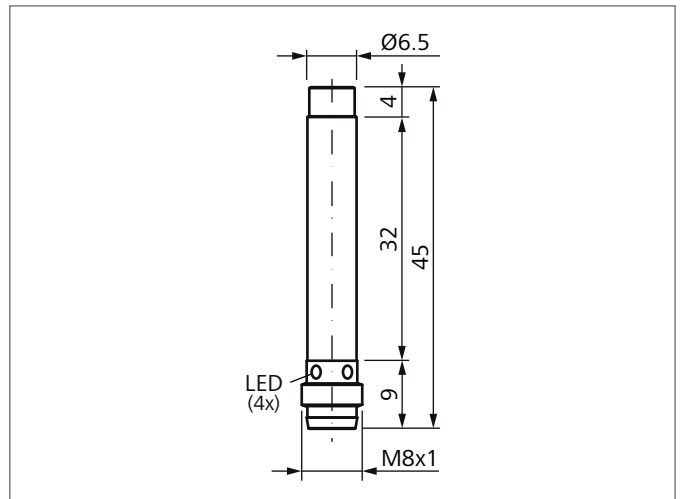

TECHNICAL INFORMATION (typ.)		+20°C, 24V DC
操作原理		电感式
评估		数字的
尺寸		6,5 mm (直径)
设计		圆柱形
安装		非齐平
工作距离		4 mm
标准化的测量板		9 x 9 x 1 mm
工作电压		10 ... 30 V DC
开关输出		pnp, 200 mA, NO
开关滞后		< 10 %
LED指示灯		是
负载振荡		10 ... 55 Hz / 1,0 mm / 30 g
压降		< 2,0 V
工作频率		< 1000 Hz
环境温度		-25 +70 ° C
防护等级		IP 67
防护等级		III,在保护性低电压下工作
外壳材料		brass chromium-plated
连接		Connector, M8