

ID-100-IM3-2-US

Lecteur portatif

- Dual zone optic: fast and reliable decoding despite fluctuating working distances
- Able to read every kind of 1D and 2D codes – coloured and low-contrast as well as damaged ones
- Low weight for fatigue-free working
- Read-feedback by means of LED, audible sound and vibration



CE

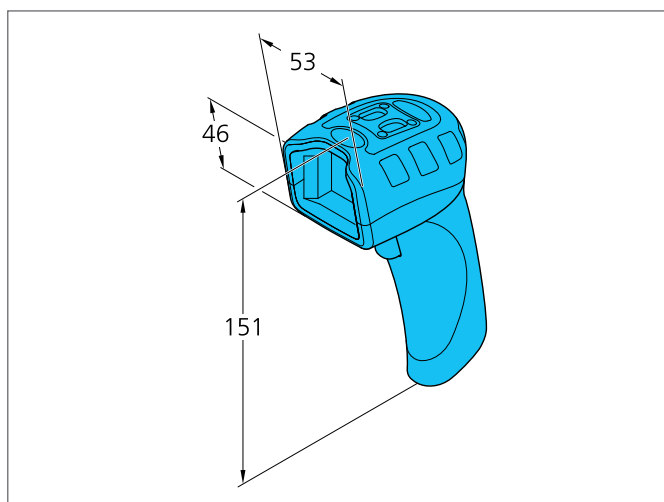
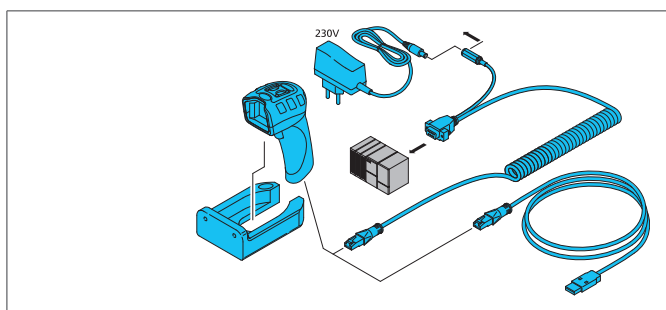

Safety instructions

The Instruments are not to be used for safety applications, in particular applications in which safety of persons depends on proper operation of the instruments.
These instruments shall exclusively be used by qualified personnel.

OPEN SOURCE SOFTWARE NOTICE

Please note we use Open Source Software along with this product and/or this product firmware.

CARACTÉRISTIQUES TECHNIQUES (typ.)

	+20°C, 5V DC
Tension d'alimentation	5 V DC
Courant à vide	250 mA
Résolution	1280 x 960 pixels
Interface	RS 232 (lorsqu'il utilise ID-K-SD/DCJ-RJ50-2), USB (lorsqu'il utilise ID-K-M12/U-2), USB-A (lorsqu'il utilise ID-K-RJ50/U-2)
Température ambiante, fonctionnement	-20 ... +55 °C
Indice de protection	IP 54
Connexion	RJ 50
Types de code - 1D-Codes	Code 11, Code 32, Code 39, Code 93, Code 128, Interleaved 2 of 5, GS1 DataBar (RSS), BC 412, UPC / EAN, Codabar, Jata 3 of 5, Hong Kong 2 of 5, Matrix 2 of 5, MSI Plessey, NEC 2 of 5, Pharmacode, Plessey, Straight 2 of 5, Telepen, Trioptic, UPC / EAN / JAN
Types de code - 2D-Codes	Data Matrix (ECC 0-200), QR Code, Micro QR Code, Aztec Code, Code 49, Codablock F, Han Xin, Maxi Code
Types de code - Codes empilés	PDF 417, Micro PDF 417, GS1 Databar (Composite & Stacked), GS1 Composite (CC-A/CC-B/CC-C), Codablock F, Grid Matrix
Poids	130 g
Position scanner to code	Tilt 180°, Pitch ± 65°, Skew ± 60°
Capteur d'image	CMOS