

BE-F150/150-F5-K

Backlight

- High excess current factor
- Pulsed mode for inspection of fast moving objects
- Extremely powerful light for high depth of field
- Long-life thanks to intelligent thermal management
- Homogenous luminous field
- High protection class IP 67
- Robust metal casing



BN = marrone
BU = blu

Betrieb ausschließlich mit Flash-Controller an einem *Supply Class 2* - Netzteil!
Use only with flash equipment driven by a power supply *Class 2*!
A utiliser exclusivement avec un contrôleur d'impulsion connecté a une alimentation *Class 2*!

Safety instructions

The Instruments are not to be used for safety applications, in particular applications in which safety of persons depends on proper operation of the instruments.
These instruments shall exclusively be used by qualified personnel.

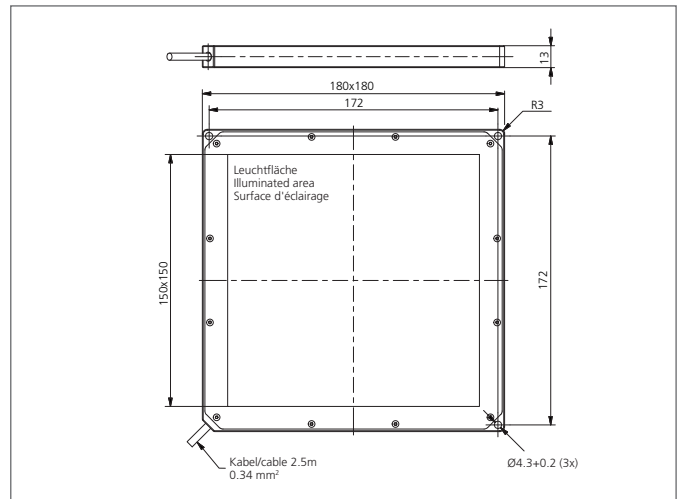

TECHNICAL INFORMATION (typ.)	
Pulse power consumption (max)	125 W
Pulse overload factor	9,6
Pulse current capacity	4800 mA
Design	Backlight
Illuminated area	150 x 150 mm
Characteristics	Flashable by means of flash controller
Light colour	White, diffuse, 6500 K
Service voltage	No constant voltage!
Shock-/vibration load	10 ... 55 Hz / 1,0 mm / 30 g
Ambient temperature, operation	0 ... +50 °C
Insulation voltage endurance	500 V
Protection class	IP 67
Risk group (DIN EN 62471)	Free group
Casing material	Aluminium black anodized
Material	PUR (Cable) PC, opal diffus (Protection optics)
Connection	Cable, 2,5 m, flying leads, Use only with flash equipment!