

DCC 12 VL 06 NOLK Inductive Proximity Switch

- For food industry
- For seawater applications
- Large sensing range to steel and aluminium
- One-piece stainless steel housing
- Protection class IP 68 and IP 69K
- Connecting cable made of TPE-S
- Integrated amplifier
- Short-circuit protection
- Starting pulse suppression
- LED

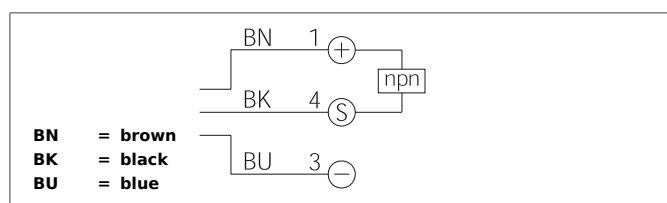
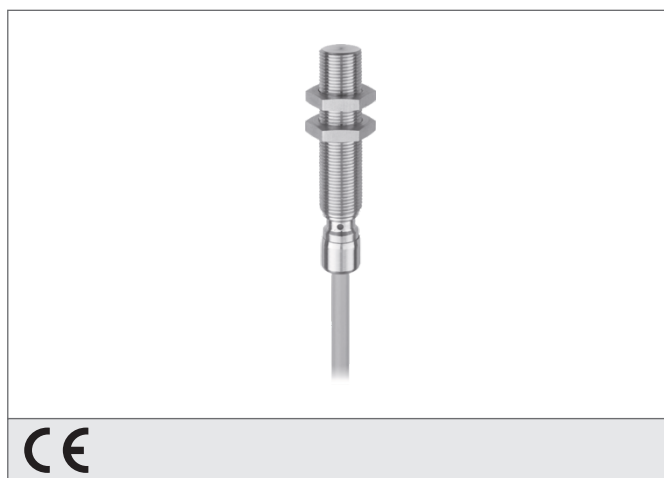

Safety instructions

The Instruments are not to be used for safety applications, in particular applications in which safety of persons depends on proper operation of the instruments.

These instruments shall exclusively be used by qualified personnel.

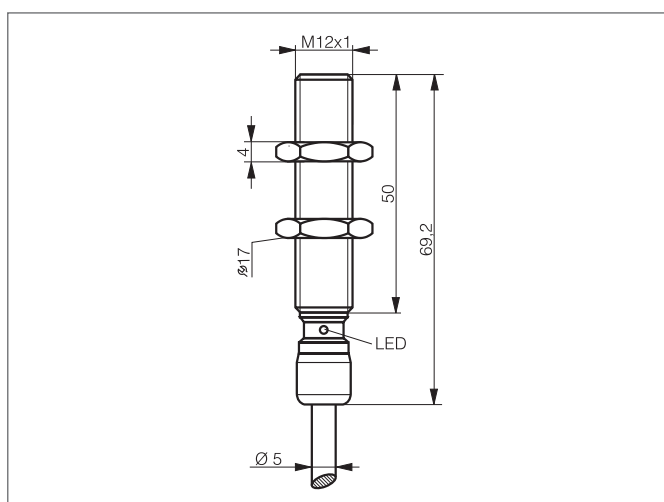

| TECHNICAL INFORMATION (typ.) | +20°C, 24V DC |
|--------------------------------|--|
| Operating principle | Inductive |
| Evaluation | digital |
| Size | M12 x 1 (thread) |
| Design | screw |
| Mounting | flush |
| Characteristics | extremely high operating distance, up to 80 bar, All stainless steel housing |
| Operating distance | 6 mm |
| Standardized measuring plate | 18 x 18 x 1 mm |
| Service voltage | 10 ... 30 V DC |
| No-load current | < 10 mA |
| Switching output | npn, 200 mA, NC |
| Switching hysteresis | < 15 % |
| Shock-/vibration load | 10 ... 55 Hz / 1,0 mm / 30 g |
| Voltage drop | < 2,0 V |
| Switching frequency | 600 Hz |
| Ambient temperature, operation | -25 ... +85 °C |
| Insulation voltage endurance | 500 V |
| Protection class | IP 68, IP 69K |
| Casing material | stainless steel (1.4435 / AISI 316L) |
| Material | TPE-S (Cable) |
| Connection | Cable, 2,0 m |