

## SA 6 Standard fixing brackets

- 结实耐用的设计
- 一套产品，包含发射器和接收器用的必要支架



### Safety instructions

All the installation, connection and safety regulations, as per our technical information, have to be strictly adhered to.

The set-up of the products have to be made by skilled staff, only.

Repair exclusively made by di-soric.

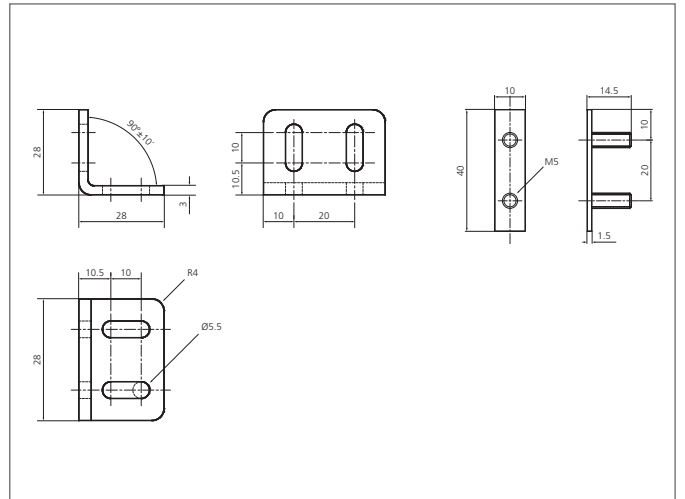

### TECHNICAL INFORMATION (typ.)

操作原理

标准固定支架

为了

all light curtains / -grids with a protected height starting from 1210 mm

材料

镀锌的金属 (安装支架)

交货范围

6个标准固定支架, Fixing material