

- 检测距离最大可达5米
- 集成的放大器电子元件
- 推挽式晶体管输出
- 高功能储备
- 非常抗脏
- 调节简单
- 有多种不同的设计
- 高防护等级
- 紧凑的设计

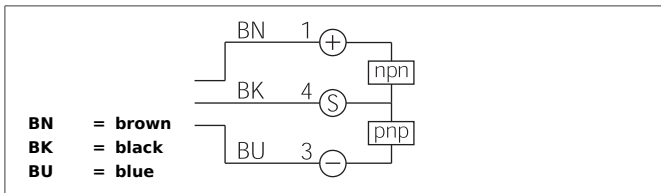

Safety instructions

The Instruments are not to be used for safety applications, in particular applications in which safety of persons depends on proper operation of the instruments. These instruments shall exclusively be used by qualified personnel.

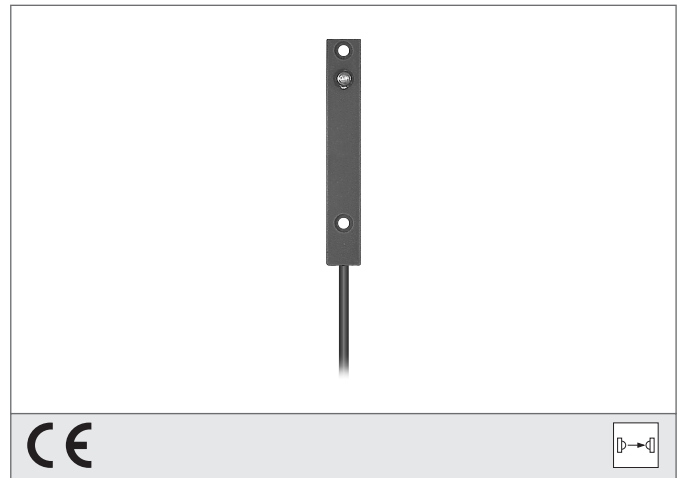
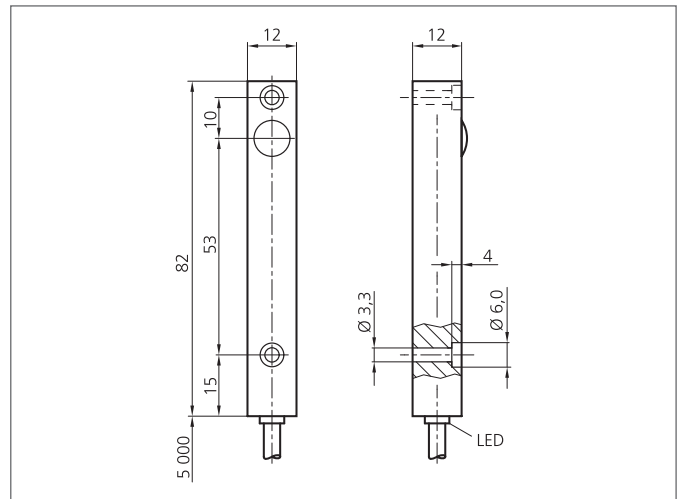

TECHNICAL INFORMATION (typ.)		+20°C, 24V DC
操作原理		对射传感器, 接收器, 开关输出
评估		数字的
尺寸		82 x 12 x 12 mm (尺寸)
设计		方形设计
特征		High transmit power and dirt penetration
工作电压		10 ... 35 V DC
内部功耗		< 40 mA
工作距离		0 ... 5,000 mm dependent on the transmitter
灵敏度调节		没有设置元素
开关输出		推挽式, 200 mA, NO
负载振荡		10 ... 55 Hz / 1,0 mm / 30 g
工作频率		500 Hz
环境温度		-20 +60 °C
环境光免疫		15 kLx, 阳光, 2 kLx, g
防护等级		IP 67
防护等级		III, 在保护性低电压下工作
外壳材料		Aluminium anodized
材料		PVC (电缆)
连接		Cable, 5,0 m