

OR 18-1 FK 5700 N3

Retroreflective Sensor

- Universal mounting possibility
- Low installation depth
- Sensitivity adjustable
- LED indicator for output state
- Plastic housing

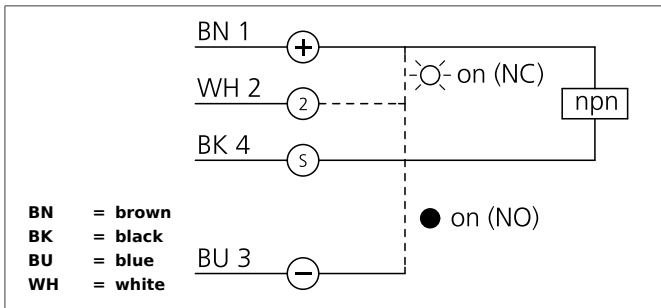

Safety instructions

The Instruments are not to be used for safety applications, in particular applications in which safety of persons depends on proper operation of the instruments.

These instruments shall exclusively be used by qualified personnel.

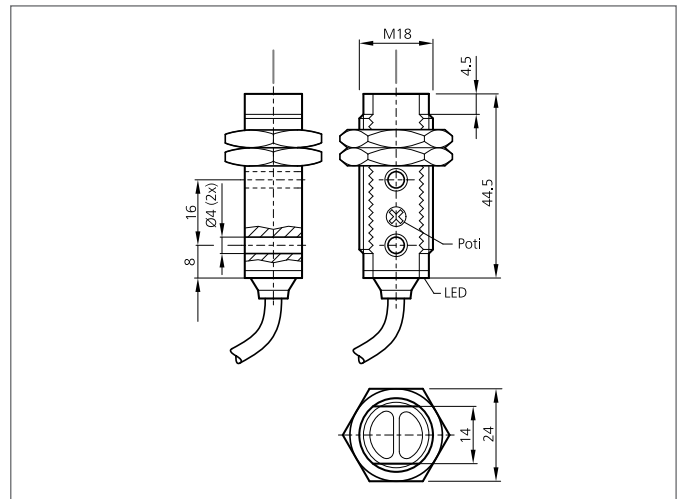

TECHNICAL INFORMATION (typ.)		+20°C, 24V DC
Operating principle		Retroreflective sensor
Evaluation		digital
Size		M18 x 1 (thread)
Design		screw
Characteristics		Reflector R 46 included
Emitted light		Red, 660 nm, clocked
Service voltage		10 ... 30 V DC
No-load current		30 mA
Notee, powered by		3000 mm (R 46) 5700 mm (R 84) 6000 mm (R 100x100)
Sensitivity adjustment		potentiometer
Referring reflector		R 46, (included)
Switching output		npn, 100 mA, NO/NC
Shock-/vibration load		10 ... 55 Hz / 1,0 mm / 30 g
Voltage drop		< 2,0 V
Switching frequency		1000 Hz
Response-/release time		0,50 ms / 0,50 ms
Ambient temperature, operation		-25 ... +55 °C
Ambient light immunity		3 kLx, clocked light, 10 kLx, Sunlight
Protection class		IP 67
Protection degree		III, operation on protective low voltage
Casing material		ABS

OR 18-1 FK 5700 N3

Retroreflective Sensor



TECHNICAL INFORMATION (typ.)

+20°C, 24V DC

Material	polymethyl methacrylate (Window) PVC (Cable)
Connection	Cable, 2,0 m