

WRB 120 S-SG-M4-2.5

Glass fiber optic

- To operate colour sensors with fibre optic connection
- High-quality glass fibres
- Arrangement of fibres statistically mixed
- Resistant to high temperature
- Robust, highly flexible

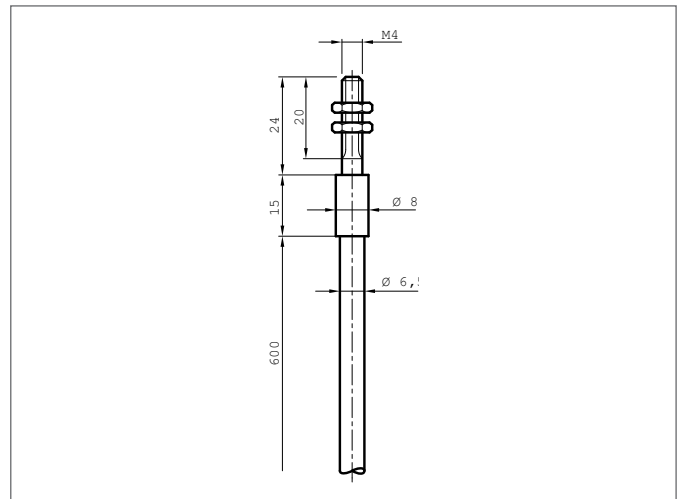
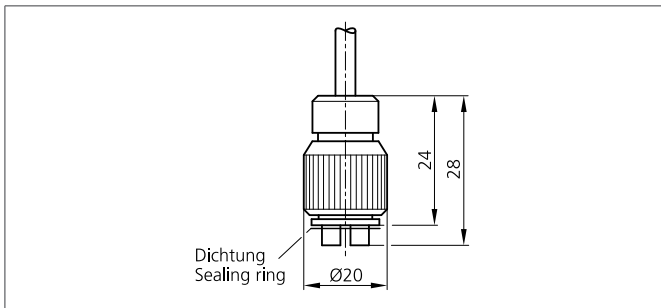

Safety instructions

The Instruments are not to be used for safety applications, in particular applications in which safety of persons depends on proper operation of the instruments.

These instruments shall exclusively be used by qualified personnel.

TECHNICAL INFORMATION (typ.)	+20°C, 24V DC
Operating principle	Diffuse reflective sensor
Design	screw
Length	600 mm, (fiber optic cable)
Dimension fiber bundles	Ø 2,5 mm
Opening angle	67°
Light outlet	axial
single fiber	Ø 0,05 mm
Bending radius	> 3 x tube-Ø
Shock-/vibration load	10 ... 55 Hz / 1,0 mm / 30 g
Temperature resistance	-40 ... + 180 °C (short-term up to +250 °C)
Protection class	IP 67
Suitable for	Colour Sensors, Amplifier for glass fiber optics
Material	Stainless steel (Sensor probe) glass fiber (Fiber) Silicone-metal sleeve (Cladding)