

WRB 120 S-SG-M6x30-2.5

Glass fiber optic

- To operate colour sensors with fibre optic connection
- High-quality glass fibres
- Arrangement of fibres statistically mixed
- Resistant to high temperature
- Robust, highly flexible

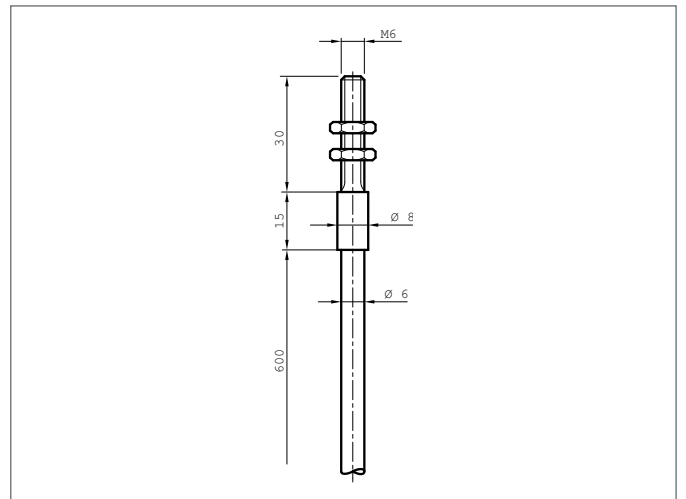
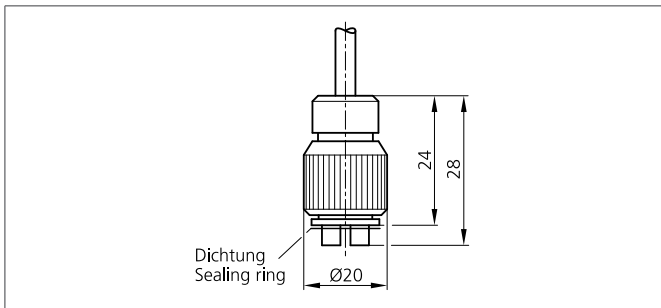

Safety instructions

The Instruments are not to be used for safety applications, in particular applications in which safety of persons depends on proper operation of the instruments.

These instruments shall exclusively be used by qualified personnel.

| TECHNICAL INFORMATION (typ.) | +20°C, 24V DC |
|------------------------------|---|
| Operating principle | Diffuse reflective sensor |
| Design | screw |
| Length | 600 mm, (fiber optic cable) |
| Dimension fiber bundles | Ø 2,5 mm |
| Opening angle | 67° |
| Light outlet | axial |
| single fiber | Ø 0,05 mm |
| Bending radius | > 3 x tube-Ø |
| Shock-/vibration load | 10 ... 55 Hz / 1,0 mm / 30 g |
| Temperature resistance | -40 ... + 180 °C (short-term up to +250 °C) |
| Protection class | IP 67 |
| Suitable for | Colour Sensors, Amplifier for glass fiber optics |
| Material | Stainless steel (Sensor probe) glass fiber (Fiber) Silicone-metal sleeve (Cladding) |