

LVHT 51 M 400 G3-B4

Laser Diffuse Sensor

- Large detection range
- Two switching points definable - window function
- Foreground and background suppression
- Teach key + remote teach with key-lock function
- Red light laser with automatic adjustment of the transmitting power
- Robust metal casing
- High protection class

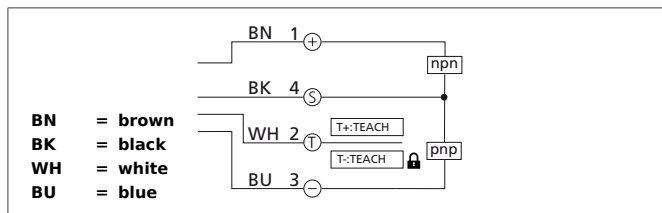

Safety instructions

Inproper use may result in hazardous radiation exposure. Pay attention to accident prevention rules and laser class. The instruments are not to be used for safety applications, in particular applications in which safety of persons depends on proper operation of the instruments. These instruments shall exclusively be used by qualified personnel.

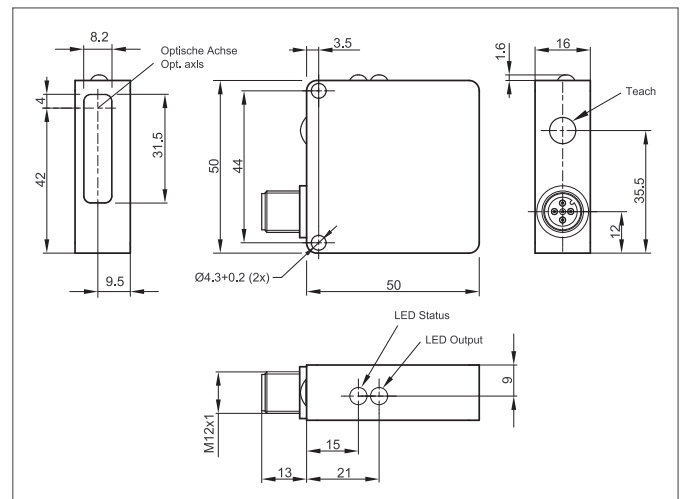

TECHNICAL INFORMATION (typ.)	+20°C, 24V DC
Operating principle	Diffuse reflective sensor
Evaluation	digital
Size	50 x 50 x 16 mm (Dimensions)
Design	cuboid design
Emitted light	Red light laser, 650 nm
Laser class	1 (IEC 60825-1)
Service voltage	10 ... 30 V DC
No-load current	60 mA, (24 V DC)
Light spot size	Ø 2 mm
Operating distance	50 ... 400 mm
Sensitivity adjustment	Teach key + remote teach
Switching output	Push pull, 150 mA, NO/NC, switchable
Switching hysteresis	0,1 %
Shock-/vibration load	10 ... 55 Hz / 1,0 mm / 30 g
Display	LED: green - operation, yellow - outputs
Voltage drop	< 2,0 V
Switching frequency	100 Hz
Reproducibility	0,5 %
Ambient temperature, operation	0 ... +50 °C
Ambient light immunity	5 kLx
Insulation voltage endurance	500 V
Protection class	IP 67
Protection degree	III, operation on protective low voltage

LVHT 51 M 400 G3-B4

Laser Diffuse Sensor



TECHNICAL INFORMATION (typ.)	+20°C, 24V DC
Casing material	Aluminium black anodized
Material	polymethyl methacrylate (Window)
Connection	Connector, M12, 4-poled
Connecting cable	VK ...