

- 亮通/暗通
- IO-Link
- 4 operating modes as IO-link parameter
- On-/off delay as IO-link parameter
- Diagnose via (by means of) IO-link
- 金属外壳
- 集成电子组件
- 灵敏度可调
- 高操作频率
- 环形LED灯
- 高防护等级
- 5-year warranty

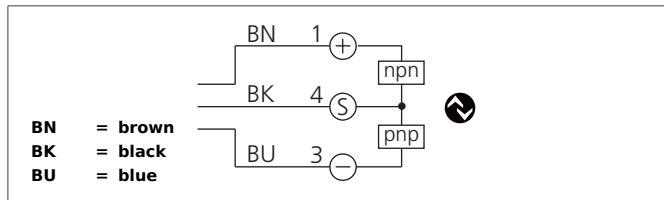

Safety instructions

The Instruments are not to be used for safety applications, in particular applications in which safety of persons depends on proper operation of the instruments. These instruments shall exclusively be used by qualified personnel.

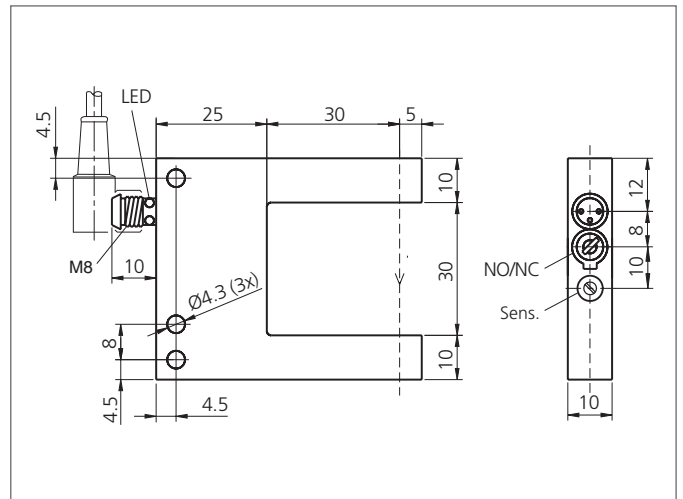

TECHNICAL INFORMATION (typ.)		+20°C, 24V DC
操作原理		光学的
评估		数字的
Operating modes		Default, High resolution, Power, Speed
尺寸		50 x 60 x 10 mm (尺寸)
设计		槽型
槽口宽度		30 mm
分支长度		35 mm
发射光		红外光, 已调制
工作电压		10 ... 30 V DC (Supply Class 2)
内部功耗		< 30 mA
分辨率		0,3 mm (min. 0,2 mm)
灵敏度调节		电位计
开关输出		推挽式, 100 mA, NO/NC, 可切换
接口		IO-Link, V1.1, COM2 (38,4kBd), Smart Sensor Profile
工作频率		5000 Hz, (< 8000 Hz)
重复定位精度		0.02 mm
环境温度		-25 +60 ° C
绝缘电压		500 V
防护等级		IP 67
防护等级		III,在保护性低电压下工作
外壳材料		Die-cast zinc black powder-coated
连接		Connector, M8, 3-poled
Connecting cable		TK ...