

SH-UGU-20-14

Sensor Holder for Fork light barriers

- Highly flexible versatile mounting system
- All-purpose mounting
- Smooth adjustment
- Robust design

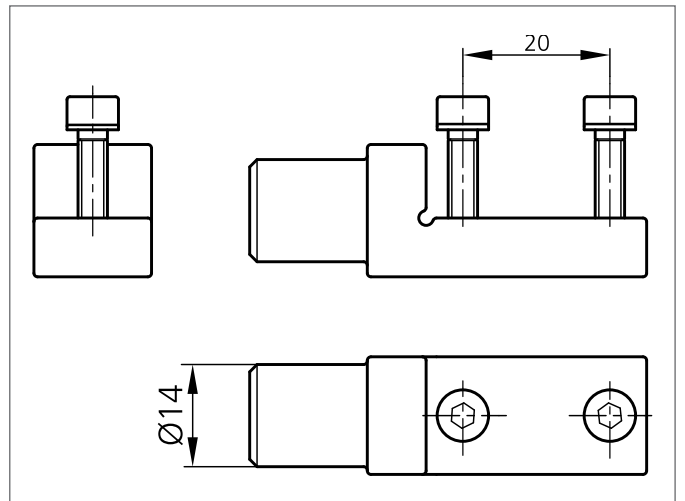
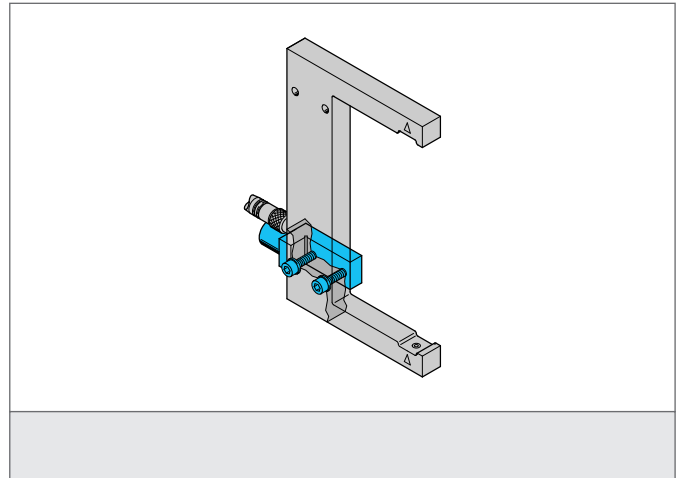

TECHNICAL INFORMATION (typ.)	
Size	+20°C, 24V DC 14 mm (Diameter A)
Suitable for	Clamping pin 20 mm
Casing material	plastics
Product series	System holder HS