

## OT 18 K 1000 P4-4 Diffuse Sensor

- Compact design
- Infrared light
- Sensitivity adjustable
- High resolution, operating frequency, functional reserve
- High scanning range
- Antivalent output

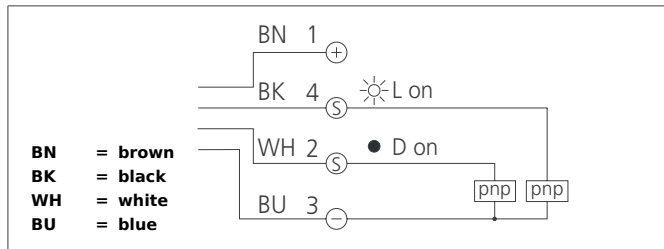
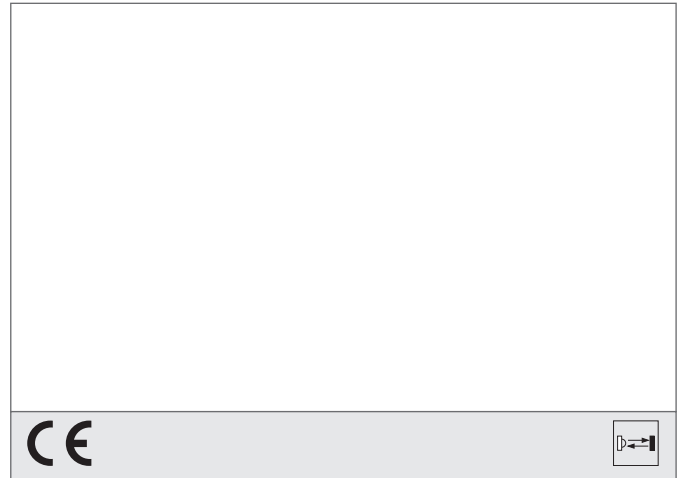

### Safety instructions

The Instruments are not to be used for safety applications, in particular applications in which safety of persons depends on proper operation of the instruments.

These instruments shall exclusively be used by qualified personnel.

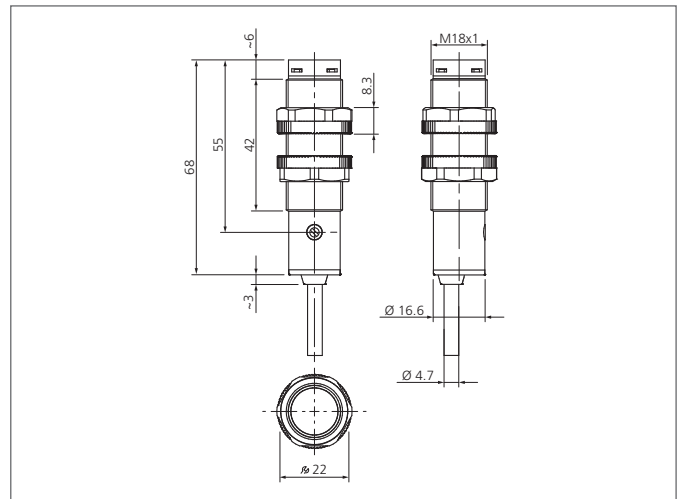

TECHNICAL INFORMATION (typ.)		+20°C, 24V DC
Operating principle		Diffuse reflective sensor
Evaluation		digital
Size		M18 x 1 (thread)
Design		screw
Emitted light		Infrared, 880 nm, clocked
Standardized measuring plate		400 x 400 mm, white
Service voltage		10 ... 30 V DC
No-load current		< 30 mA
background suppression		no
Operating distance		1000 mm
Sensitivity adjustment		potentiometer
Switching output		pnp, 100 mA, exclusive OR
Switching hysteresis		< 10 %
Voltage drop		< 2,0 V
Switching frequency		250 Hz
Response-/release time		2,0 ms / 2,0 ms
Ambient temperature, operation		-25 ... +70 °C
Temperature drift		1 mm/K
Ambient light immunity		5 kLx, Halogen light, 10 kLx, Sunlight
Insulation voltage endurance		500 V
Protection class		IP 67
Protection degree		III, operation on protective low voltage
Casing material		plastics (PBT)

**OT 18 K 1000 P4-4**  
**Diffuse Sensor**



**TECHNICAL INFORMATION (typ.)**

**+20°C, 24V DC**

Material

polycarbonate (Window)  
PVC (Cable)

Connection

Cable, 2,0 m, 4-poled, flying leads