

Safety switch

Series Safety Hinge Switch SHS

Description **SHS-A1Z-SR**

Article number **6019261010**

Circuit diagram

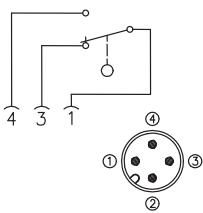

Operating diagram

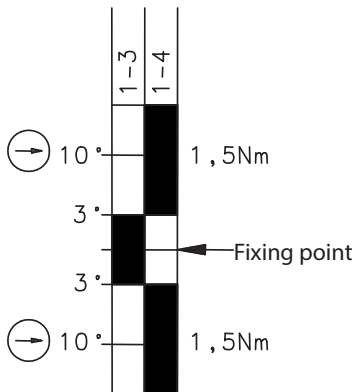

Fixing point in the range 0° ... 180° freely selectable



Tolerances:
 switching angle (opening) $+2,0^\circ / -1,5^\circ$,
 direct opening torque 10%,
 direct opening angle $+0,5^\circ / -3^\circ$
 Switching angle hysteresis
 (closing the N.C. contact $-1,0^\circ$)
 from the hinge's typical switch-off point

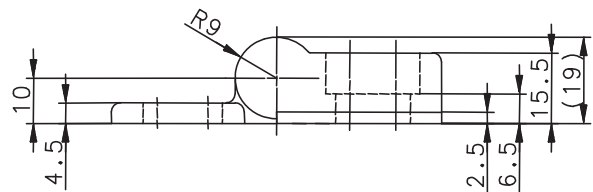
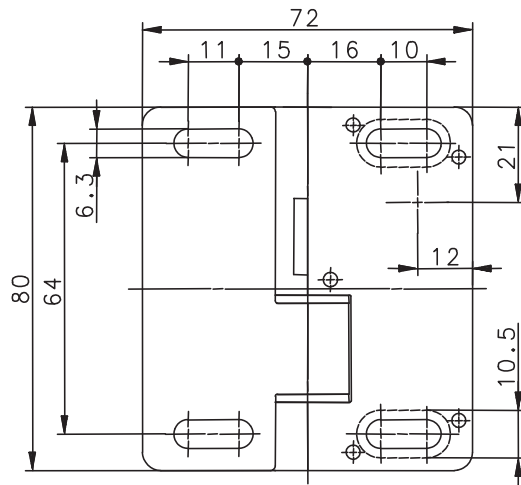

Connection

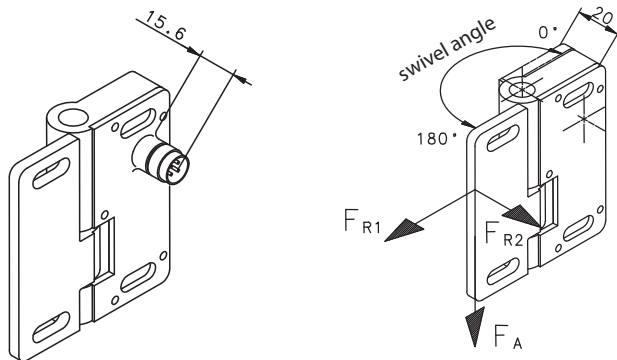

Illustration with fixed shaft and sheared-off set screw.

Electrical Data		
Rated insulation voltage	U_i	250 V
Rated impulse withstand voltage	U_{imp}	2,5 kV
Conv. thermal current	I_{the}	3 A
Rated operational voltage	U_e	230 V AC / 60 V DC
Utilization category		DC-13, 60 V DC / 0,5 A
Direct opening action	⊖	acc. to IEC/EN 60947-5-1, annex K
Short-circuit protective device		Fuse 4 A gG
Protection class		SELV

Mechanical data	
Enclosure	GD-Zn
Cover	GD-Zn
Wing	GD-Zn
Ambient air temperature	-25 °C to +70 °C
Contact type	1 Change-over
Mechanical life	1 x 10 ⁶ operating cycles
Switching frequency	max. 1200 switching operations / hour
Attachment	4 x M6 screws DIN 7984 or DIN 6912
Connection type	plug M12 x1, plastic thread
Weight	≈ 0,4 kg
Installation position	operator definable
Protection type	IP 67 in acc. with IEC/EN 60529
Switching angle	+/- 3 ° from fixing point
Direct opening angle	+/- 10 ° from fixing point
Direct opening torque	1,5 Nm
Mechanical load	F_{R1} = max. 1000 N
(see dimensioned drawing for the introduction direction of the forces)	F_{R2} = max. 500 N
	F_A = max. 750 N

ID for safety engineering	
B10d	2 x 10 ⁶ switching cycles

Standards	
	VDE 0660 T100, DIN EN 60947-1, IEC 60947-1
	VDE 0660 T200, DIN EN 60947-5-1, IEC 60947-5-1
	DIN EN ISO 13849-1

EU Conformity	
	acc. to directive 2006/42/EC

Approvals	
	$cCSA_{US}$ C300
	CCC

Notes

The safety fixture must always be attached by at least two SHS! See max. load.
If the risk assessment of the machine permits a single-channel evaluation, an empty hinge can be used as the support element.
If the SHS is used at an ambient temperature of 70 °C, it is possible that the connecting cable will age more rapidly!
The connecting cable must be protected against mechanical damage.
The cable can be installed in tubes or cable ducts.
The manufacturer / supplier of the machine / system is obligated to observe the applicable standards for the size of the safety intervals between the separating safety fixture and the hazard point.
These regulations include: EN 294, EN 349, EN 953, EN 1088,
The switch may not be used as a stop.
For a CSA/UL application it is essential to use CSA/UL approved cable for connection.
The suggested protection type (IP code), applies only when at least an equivalent cable coupling is used.